

A.M.1 Sanit. Infantil/Faldário
Escala: 1:25

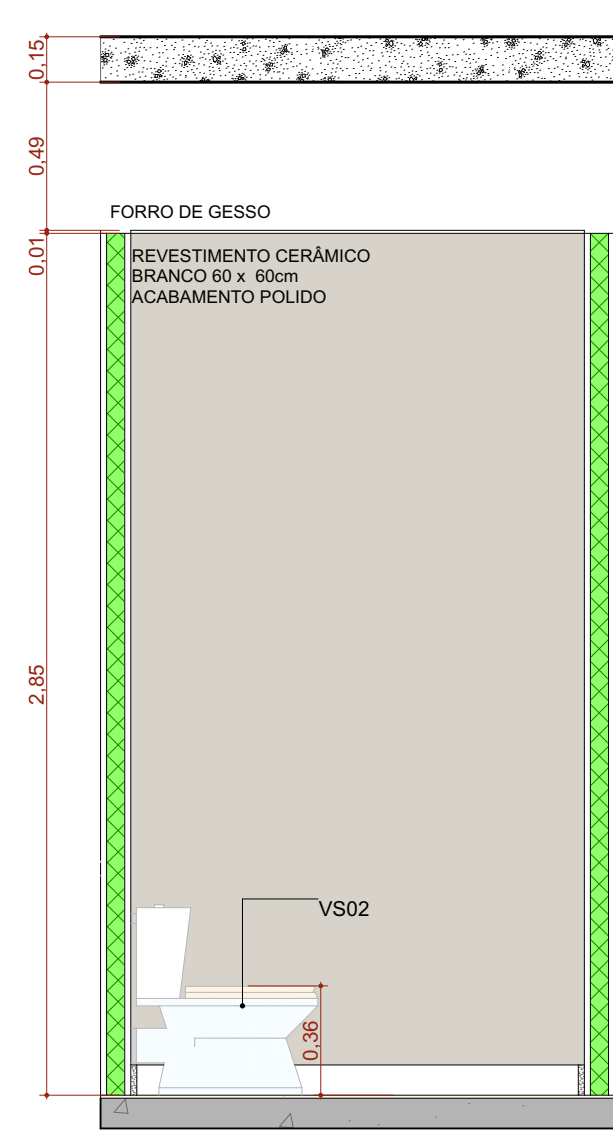

A.M.01 VISTA 1
Escala: 1:25

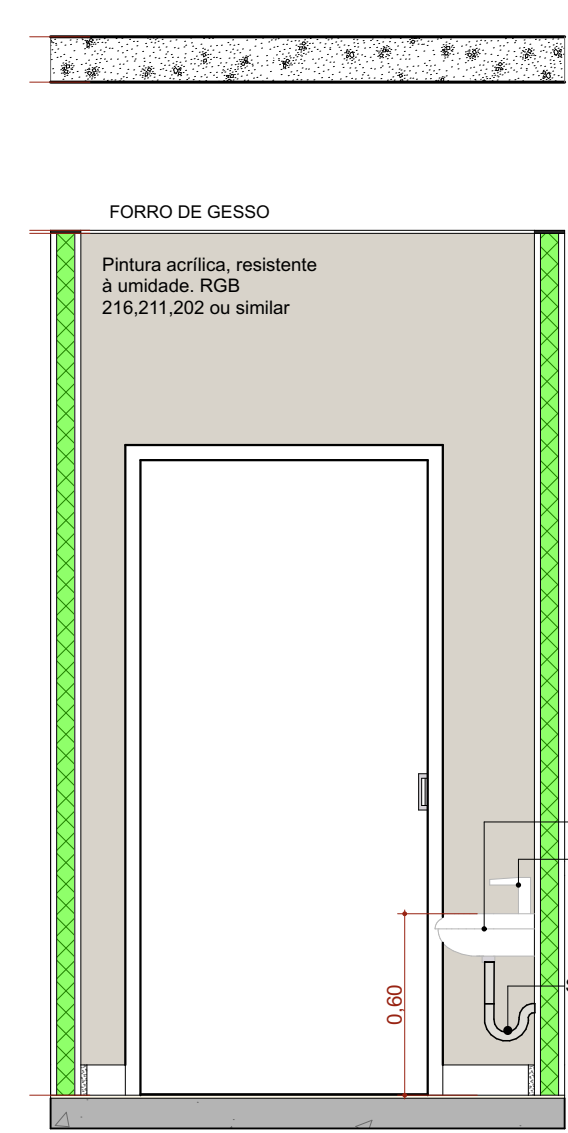

A.M.01 VISTA 2
Escala: 1:25

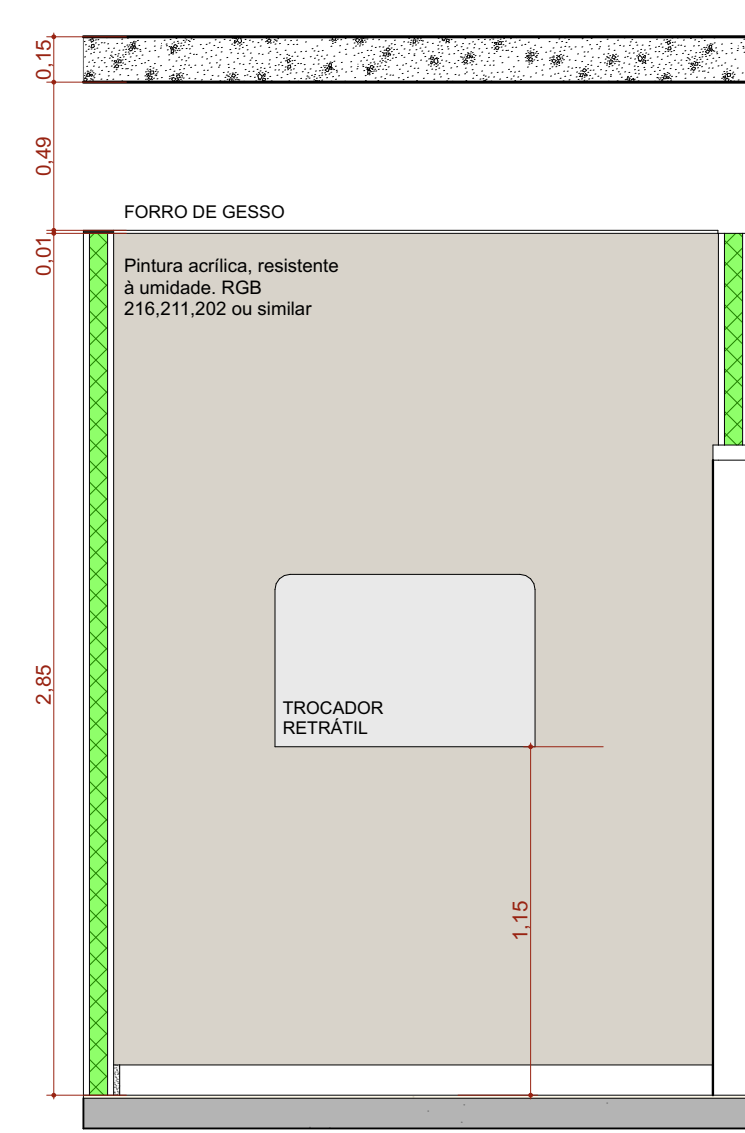

A.M.01 VISTA 3
Escala: 1:25

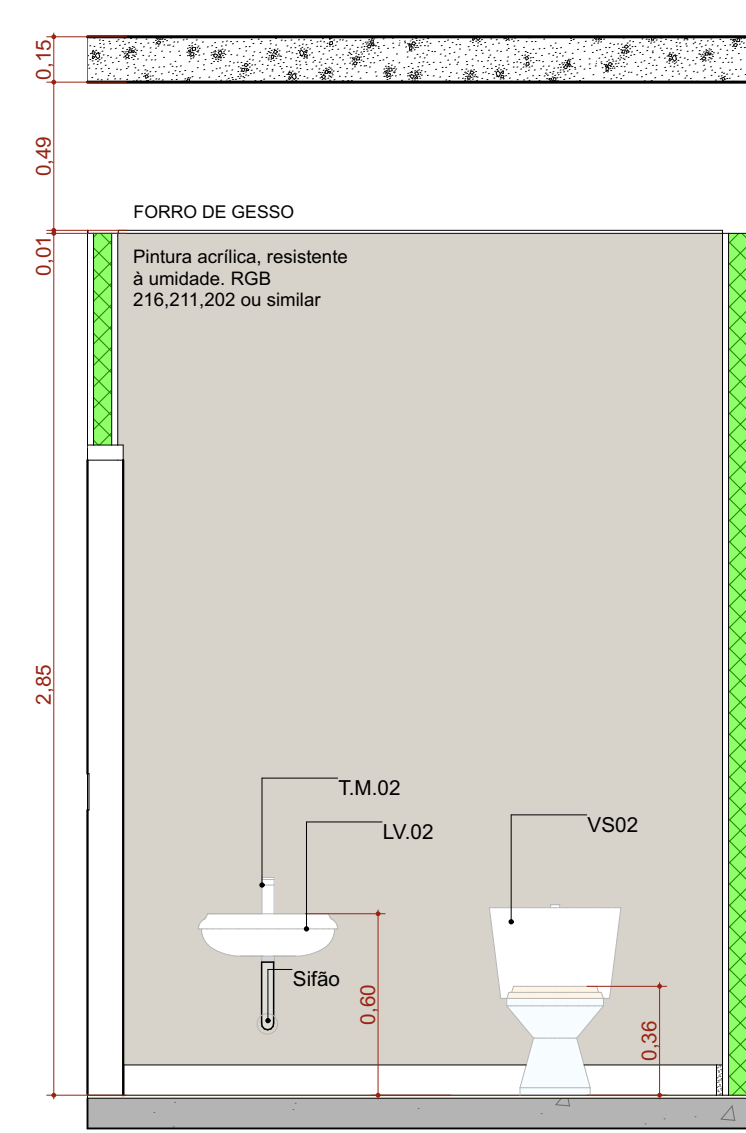

A.M.01 VISTA 4
Escala: 1:25

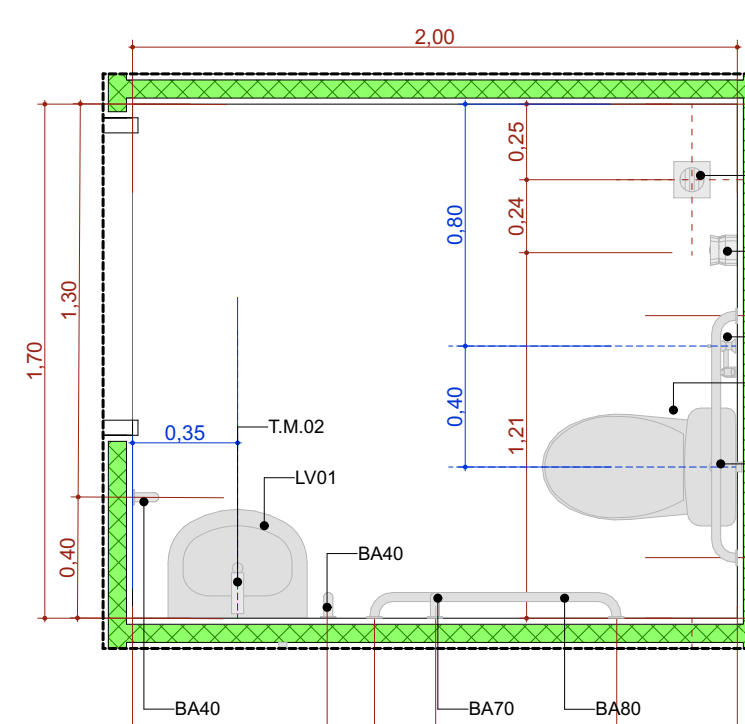

A.M.2 Sanitário PCD Fem.
Escala: 1:25

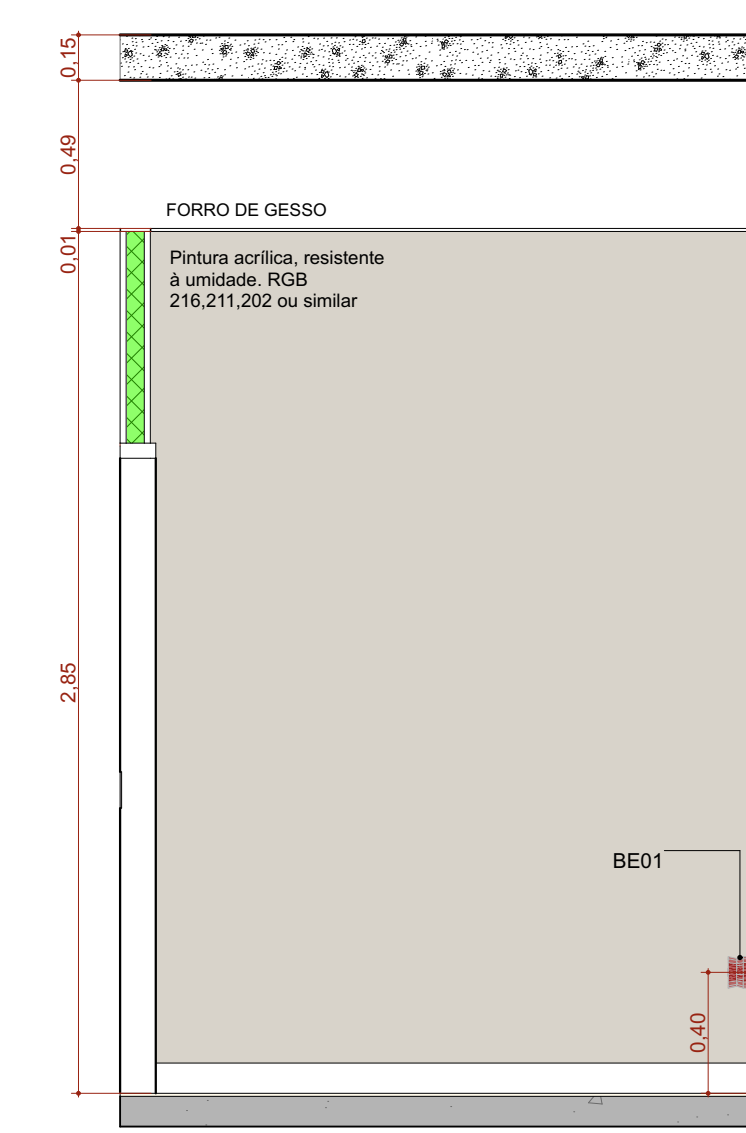

A.M.02 VISTA 1
Escala: 1:25

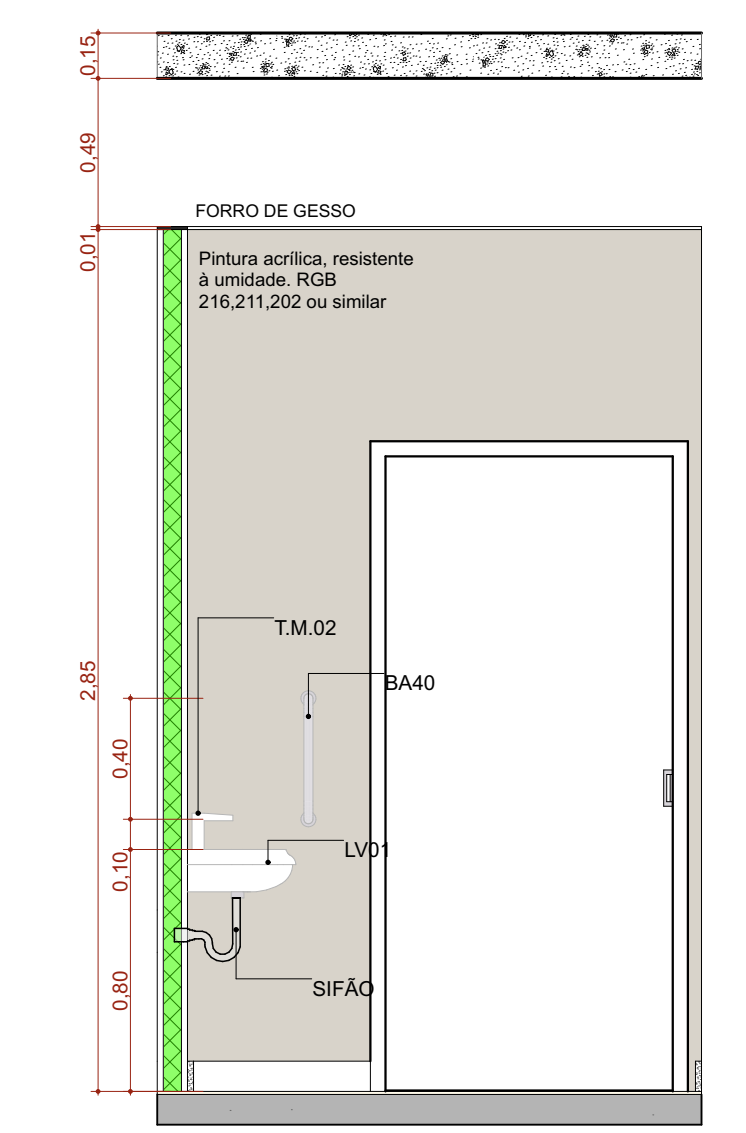

A.M.02 VISTA 2
Escala: 1:25

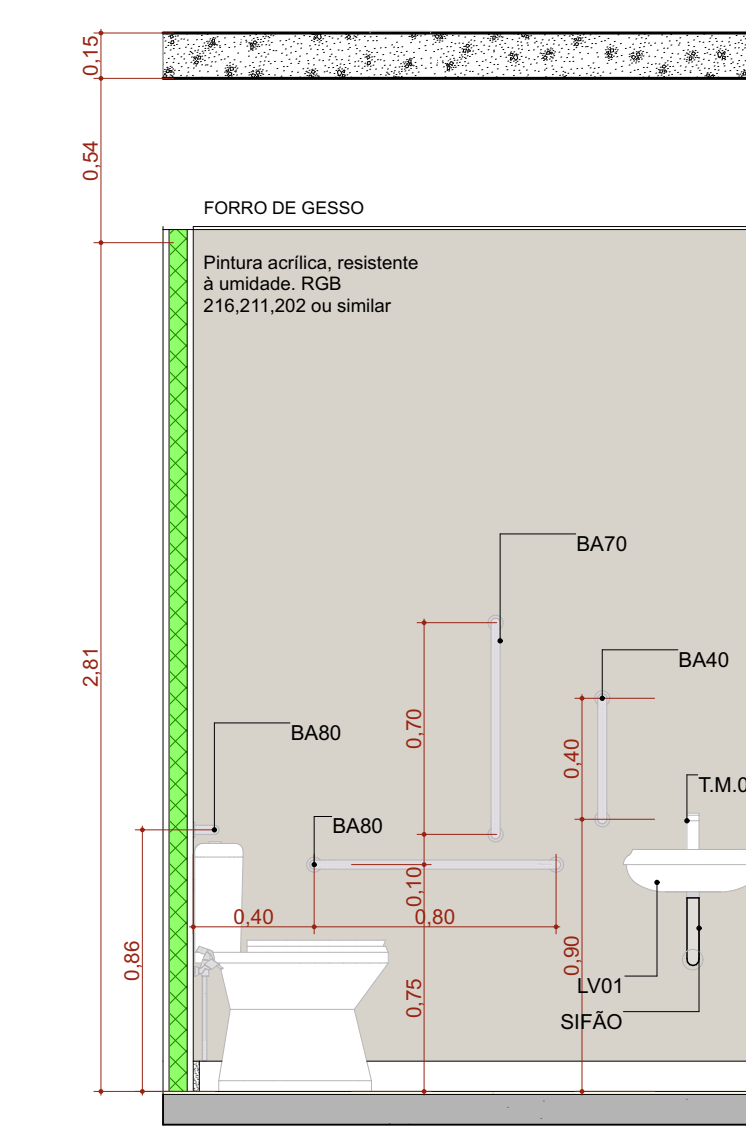

A.M.02 VISTA 3
Escala: 1:25

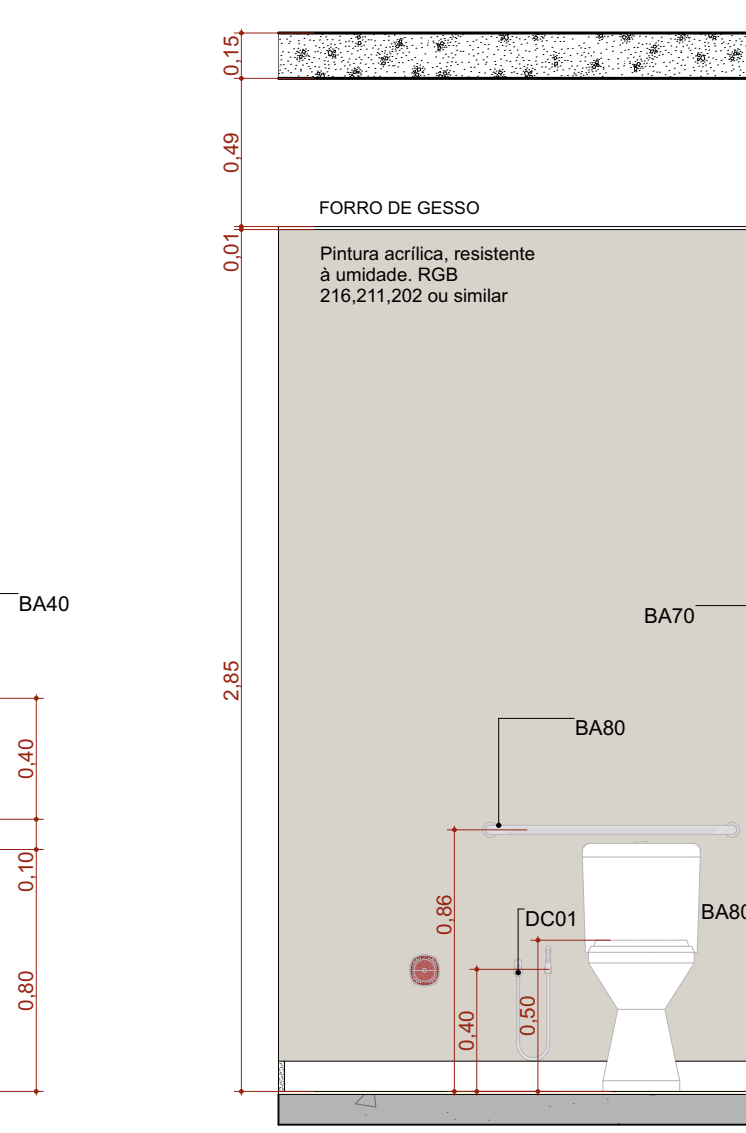

A.M.02 VISTA 4
Escala: 1:25

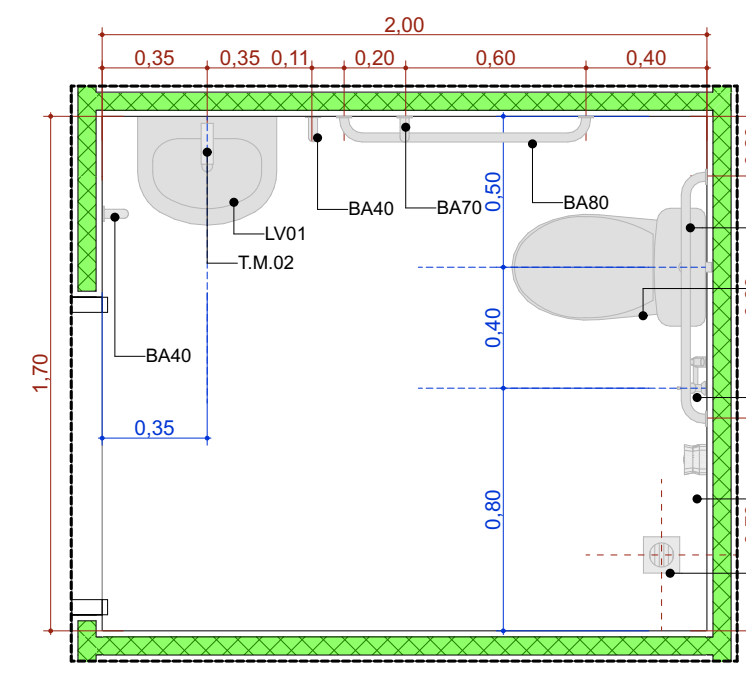

A.M.3 Sanitário PCD Masc.
Escala: 1:25

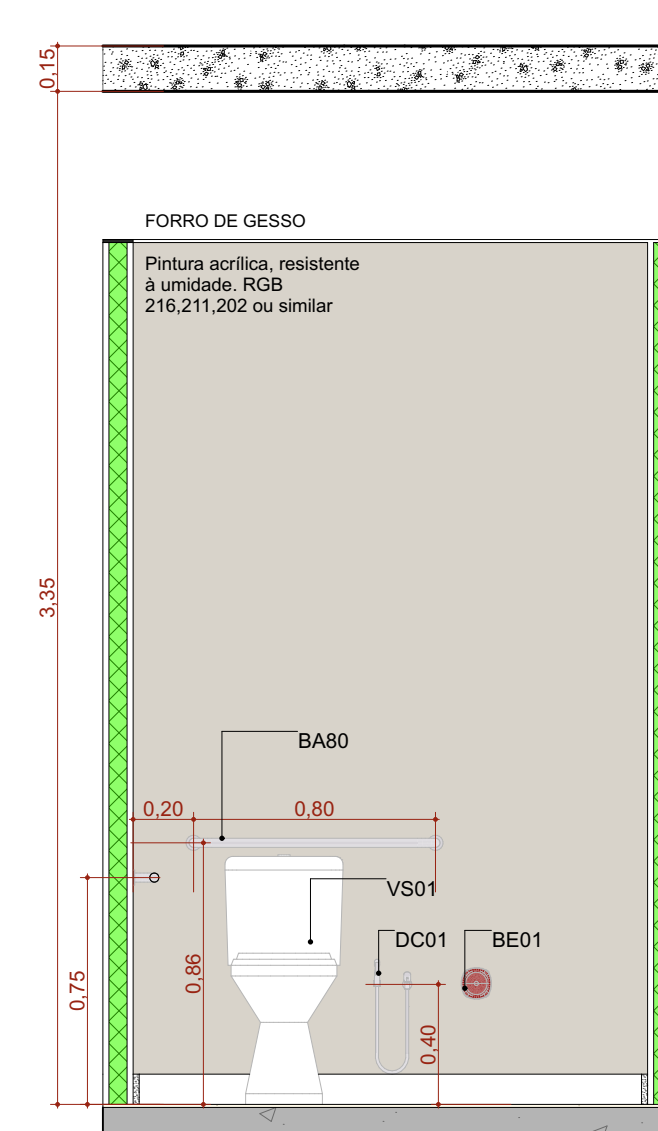

A.M.03 VISTA 1
Escala: 1:25

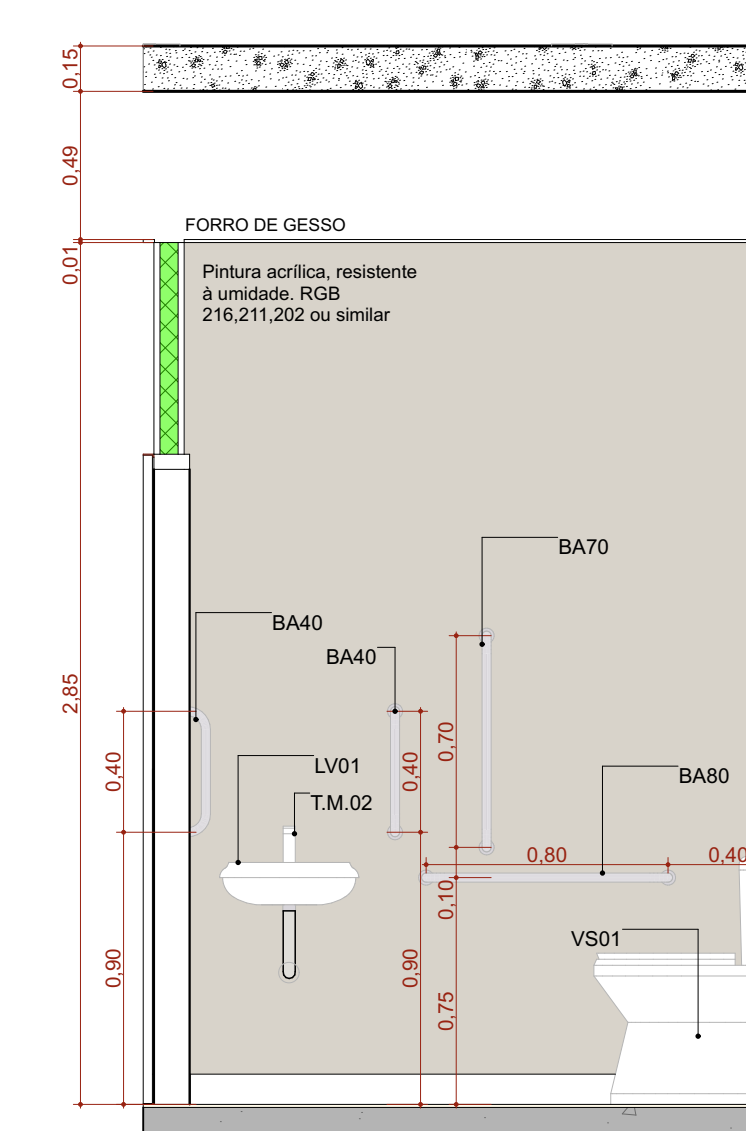

A.M.03 VISTA 2
Escala: 1:25

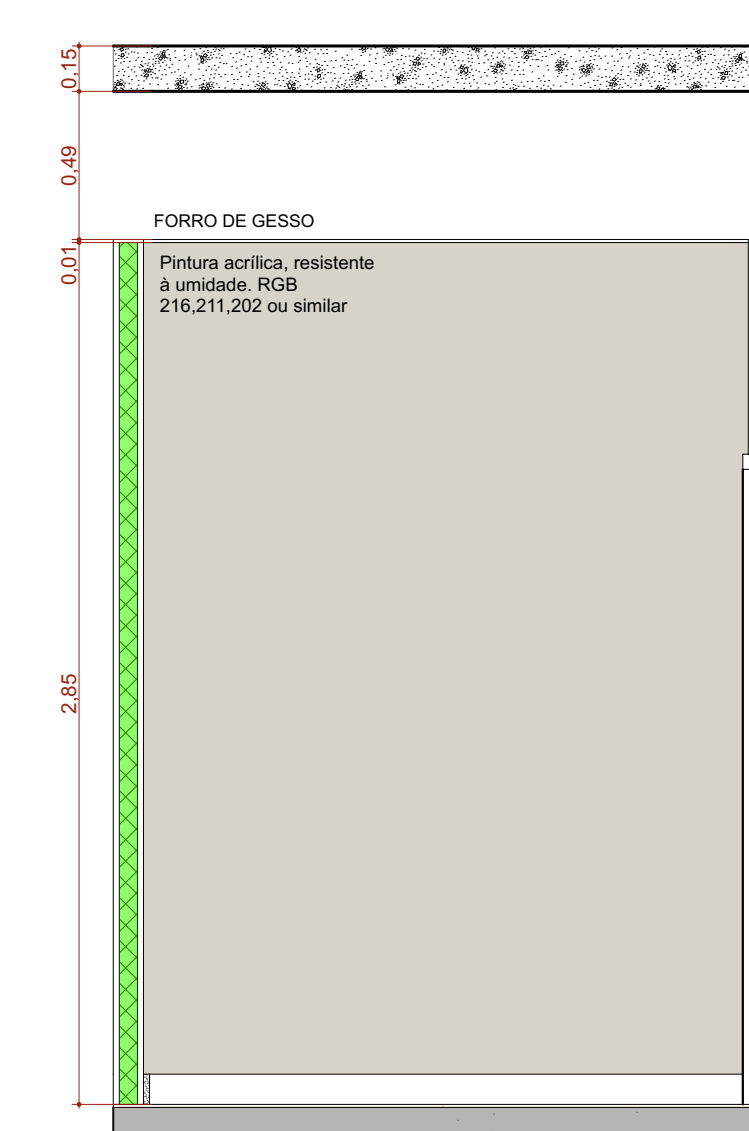

A.M.03 VISTA 3
Escala: 1:25

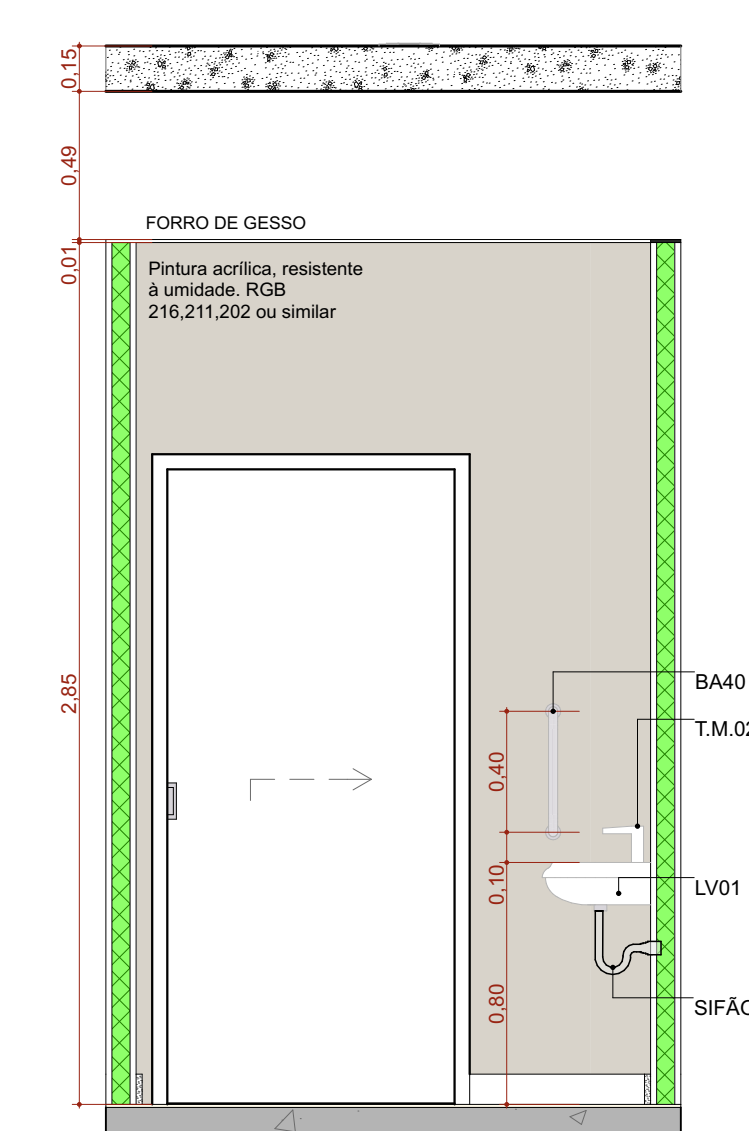

A.M.03 VISTA 4
Escala: 1:25

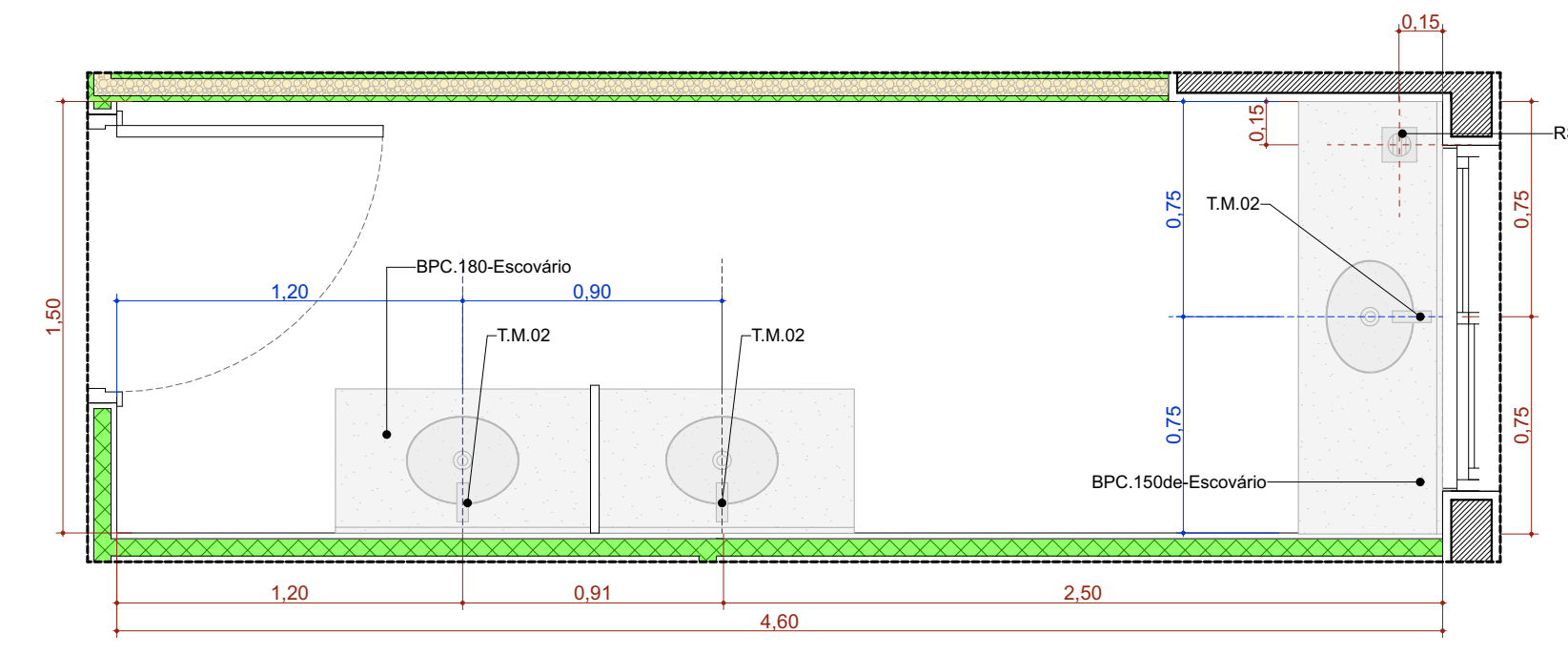

A.M.4 Educação em Saúde Bucal (Escovário)
Escala: 1:25

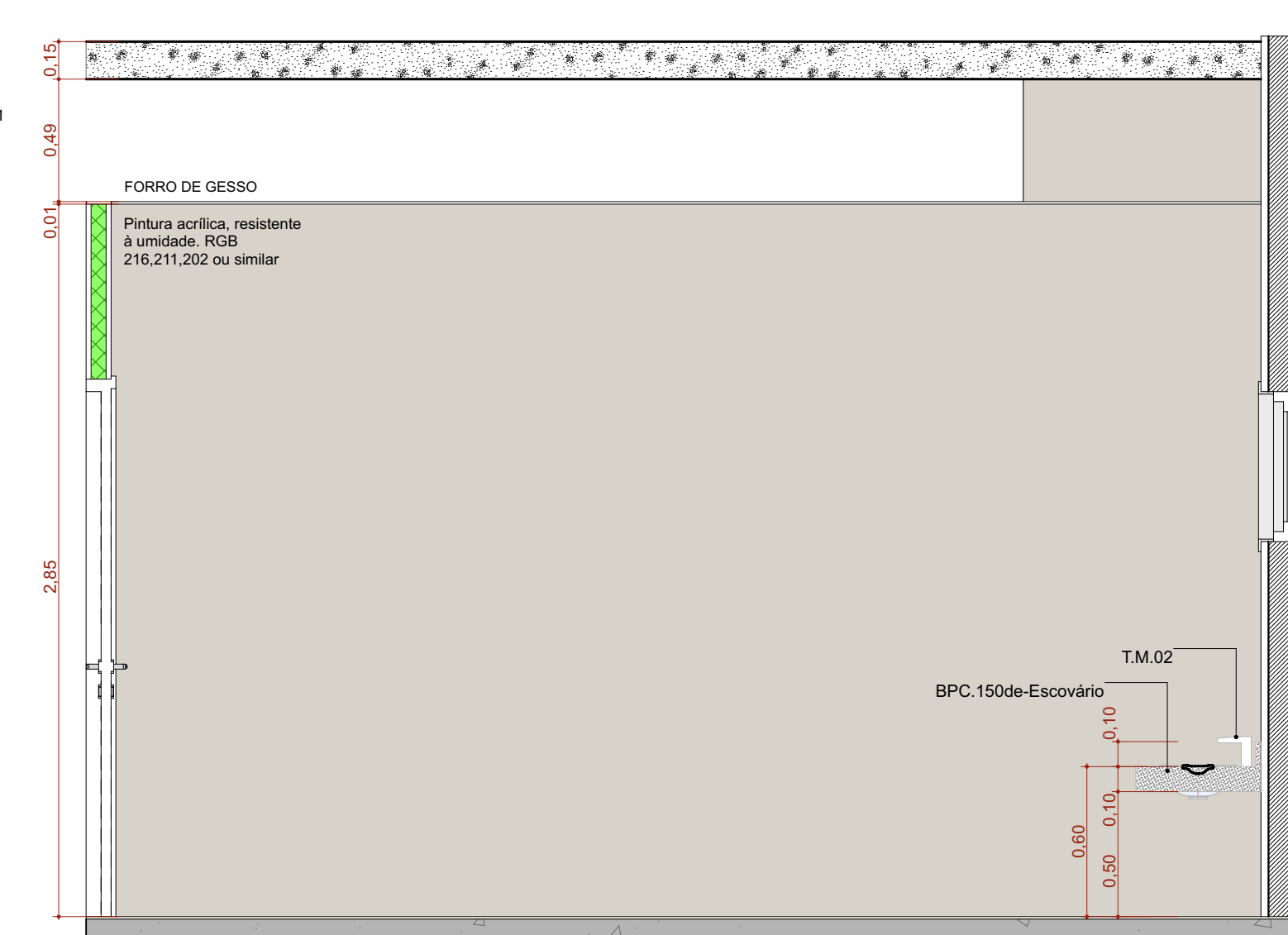

A.M.04 VISTA 1
Escala: 1:25

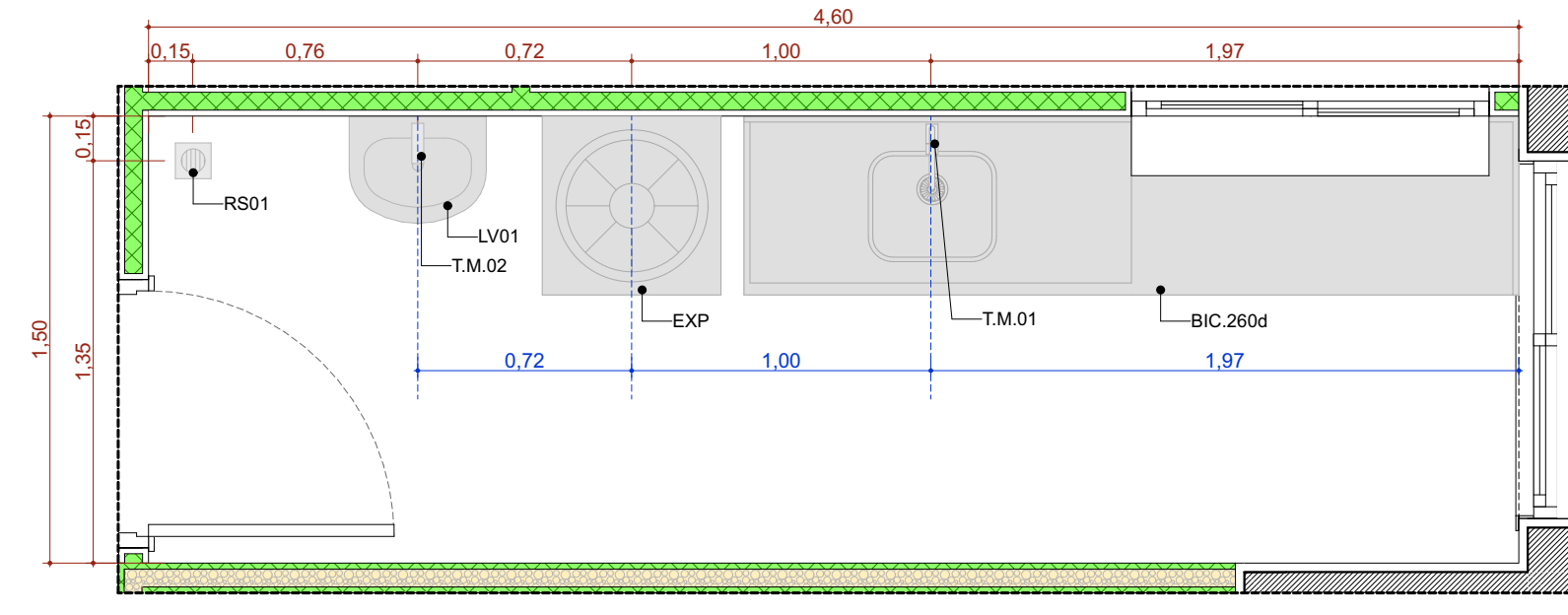

A.M.5 Expurgo
Escala: 1:25

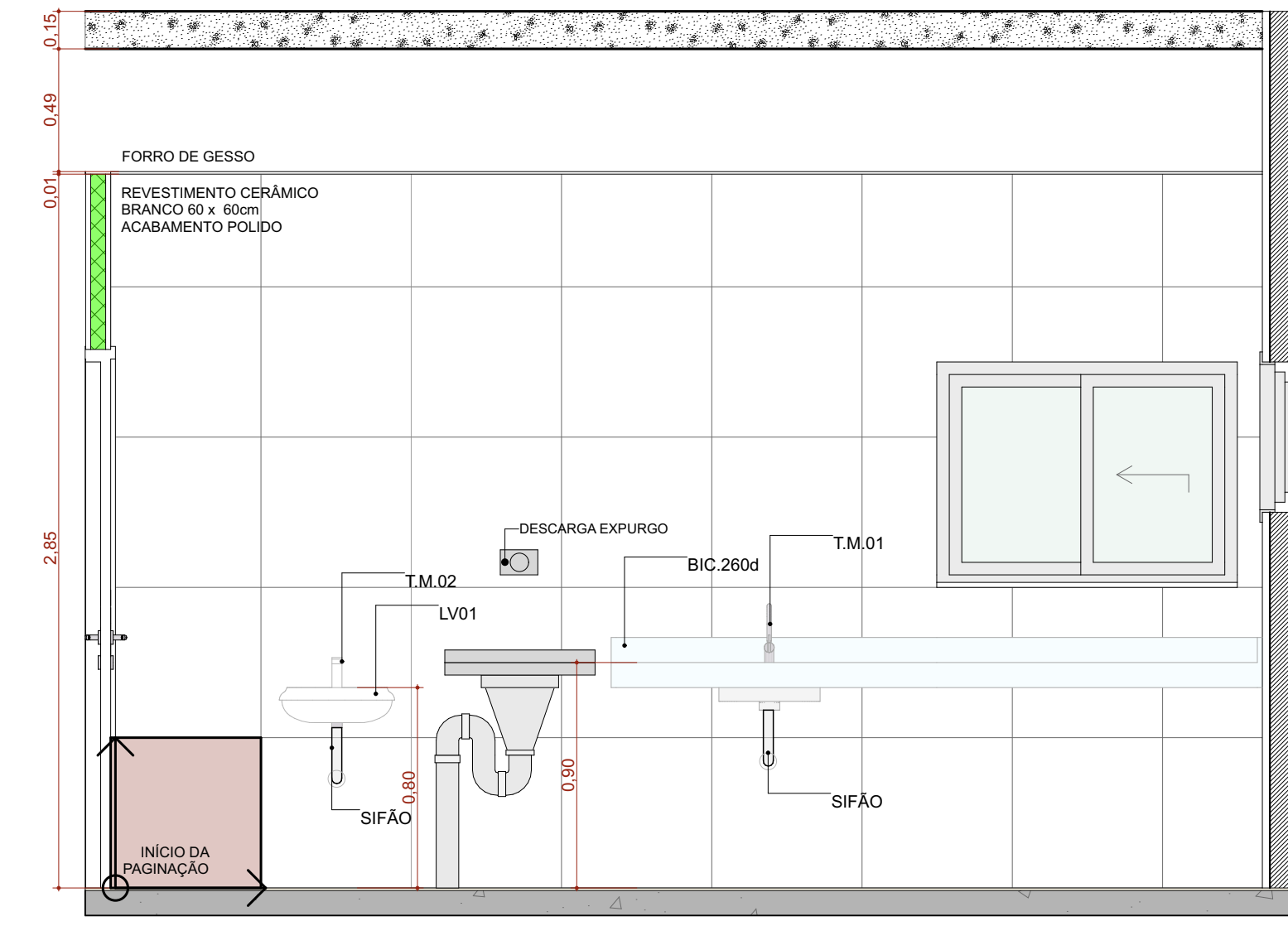

A.M.05 VISTA 1
Escala: 1:25

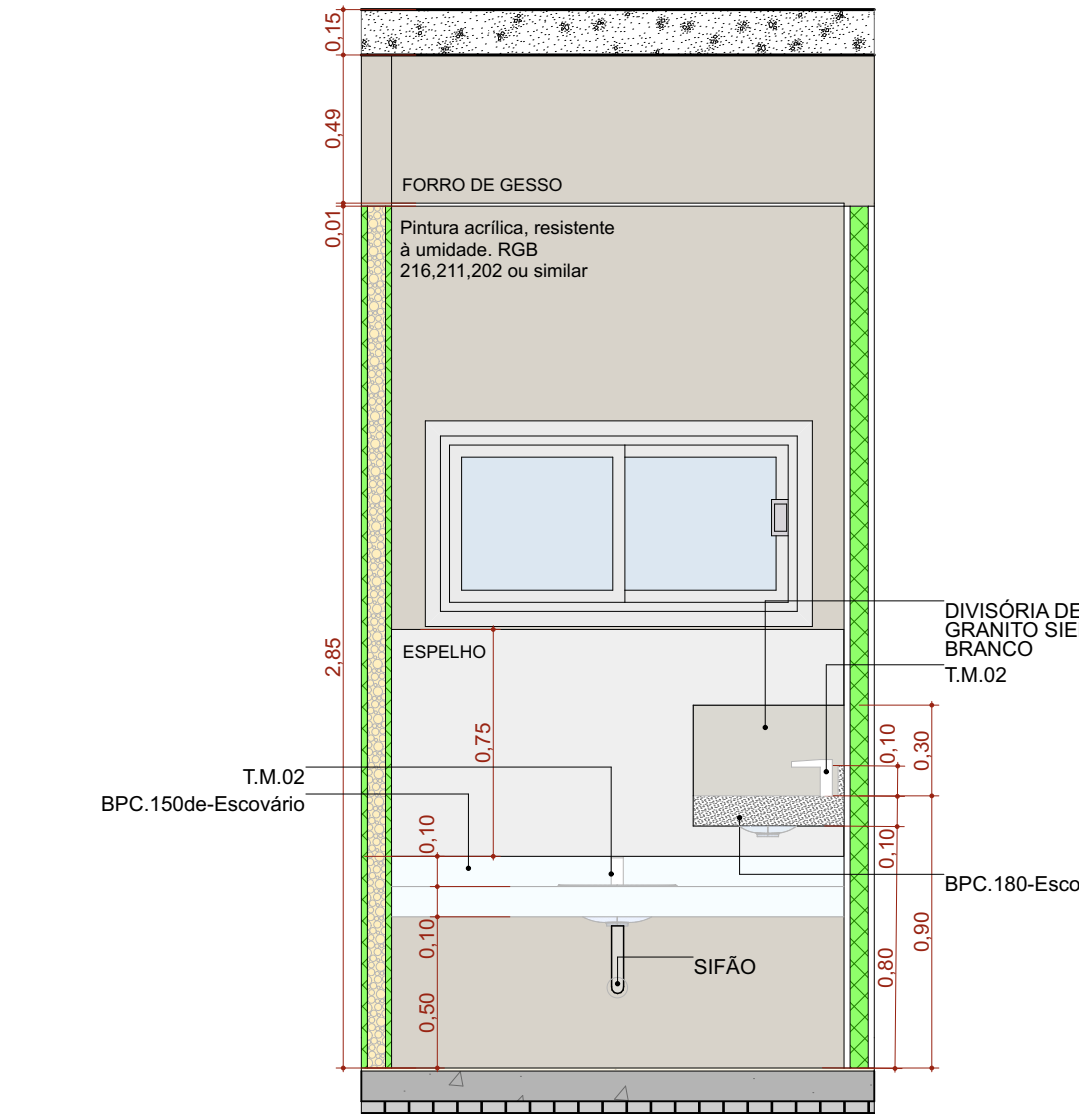

A.M.04 VISTA 2
Escala: 1:25

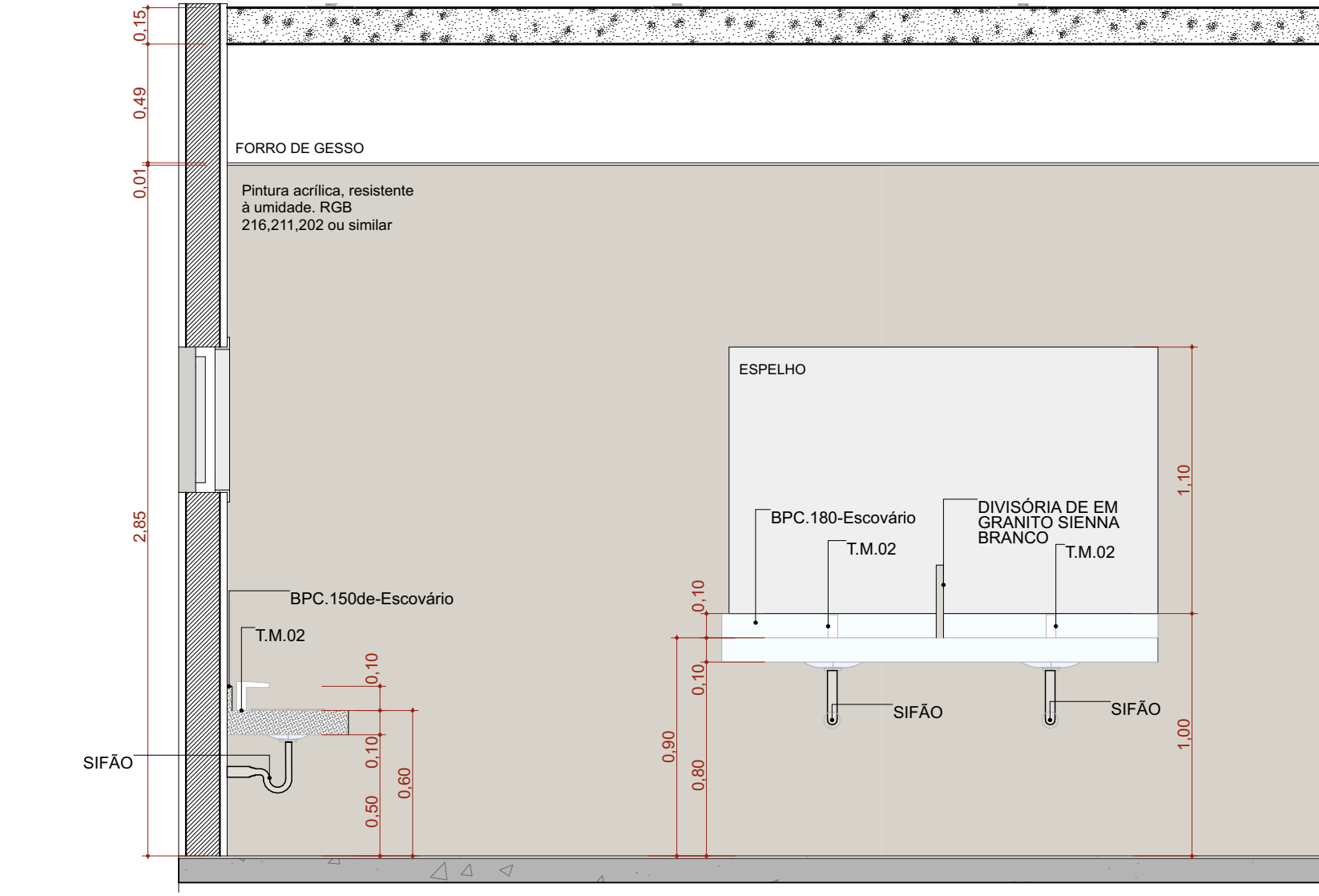

A.M.04 VISTA 3
Escala: 1:25

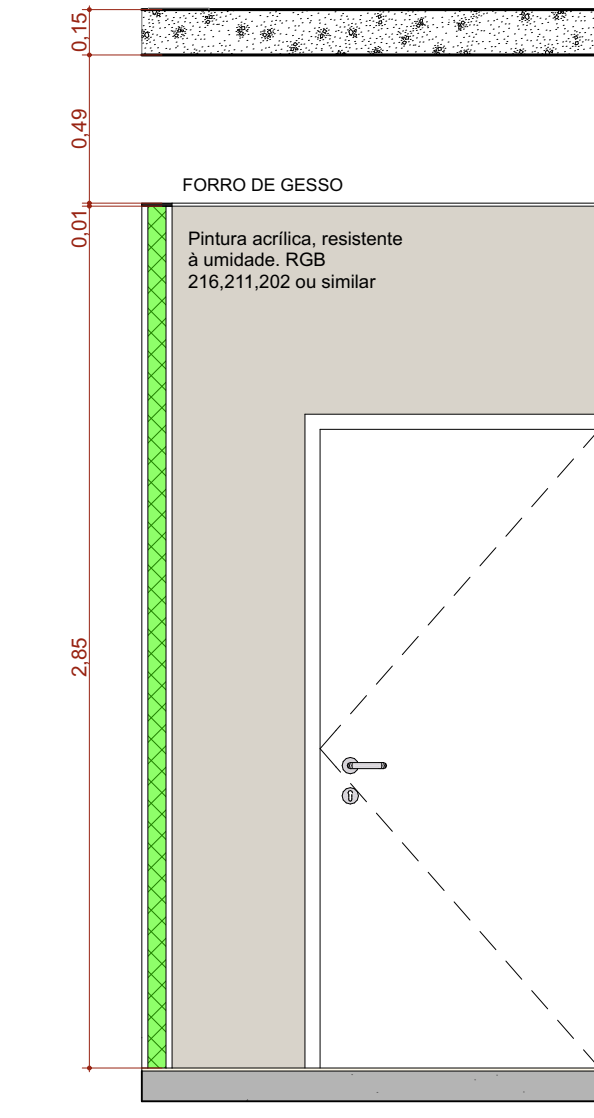

A.M.04 VISTA 4
Escala: 1:25

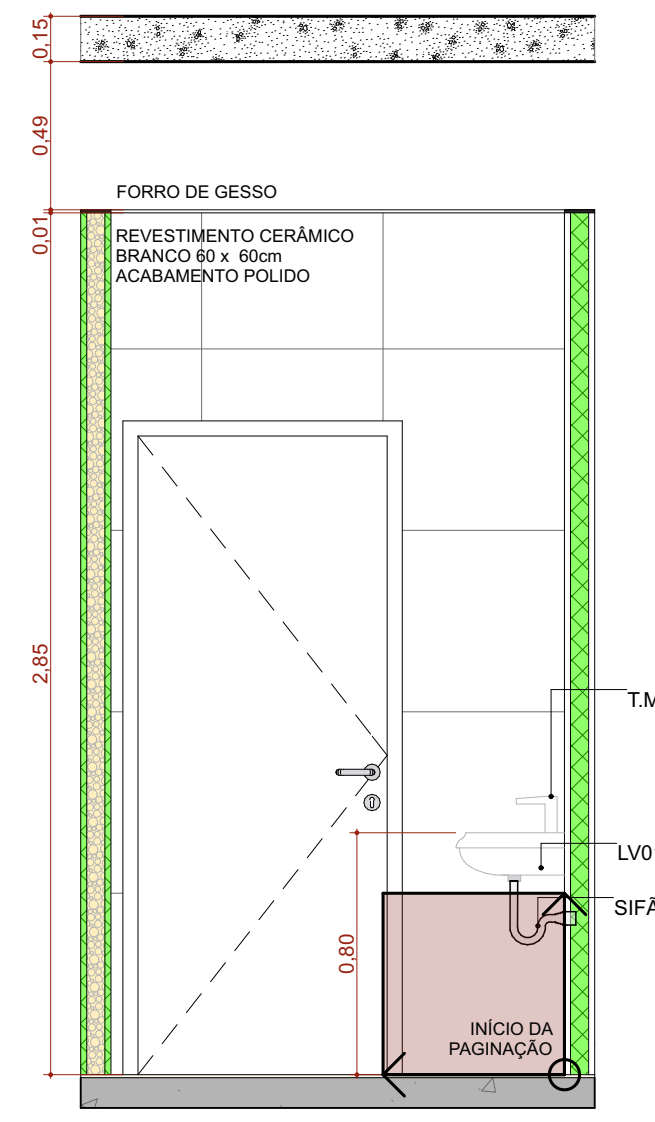

A.M.05 VISTA 2
Escala: 1:25

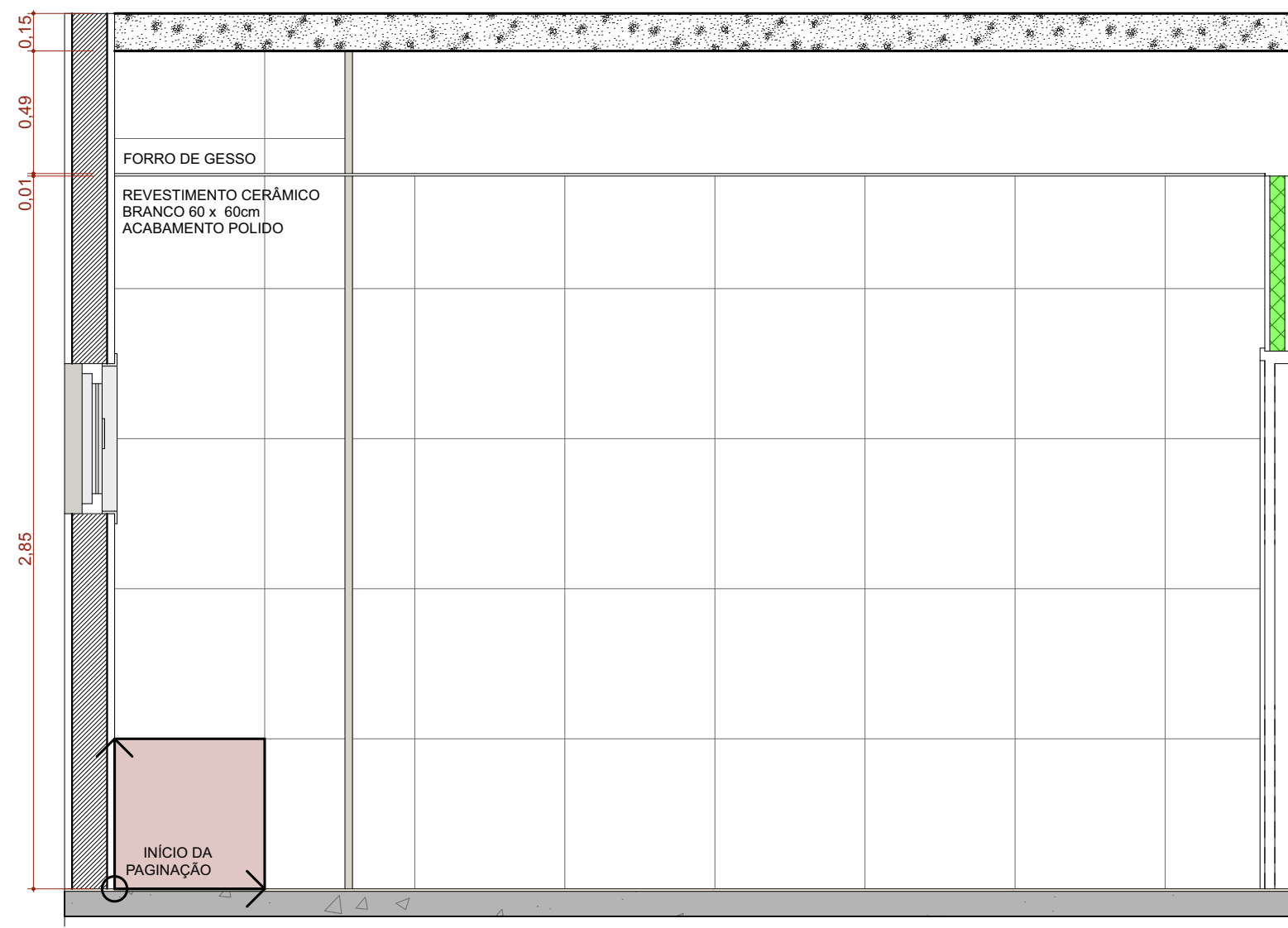

A.M.05 VISTA 3
Escala: 1:25

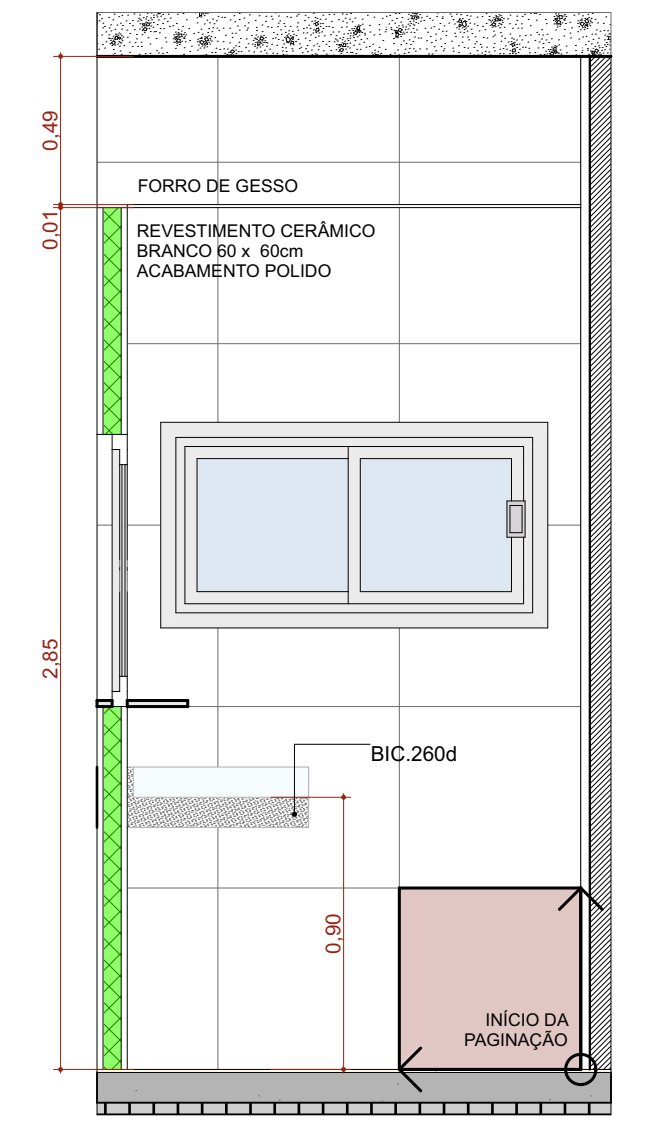

A.M.05 VISTA 4
Escala: 1:25

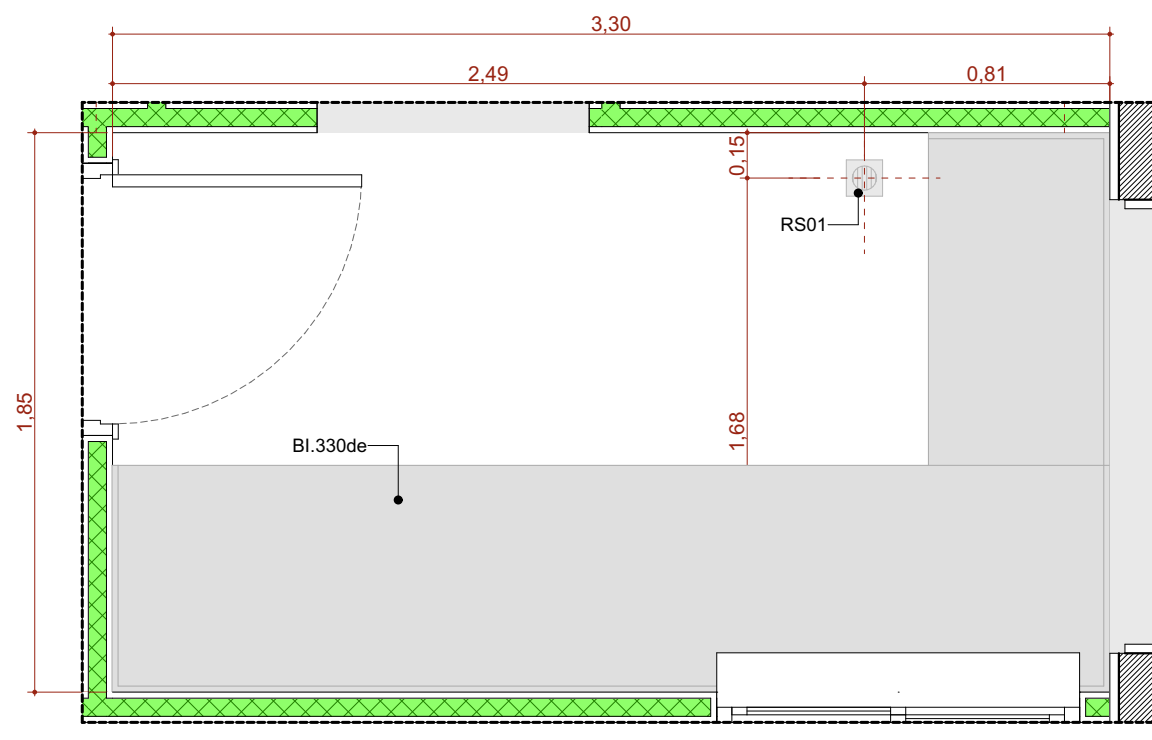

A.M.6 Esterilização
Escala: 1:25

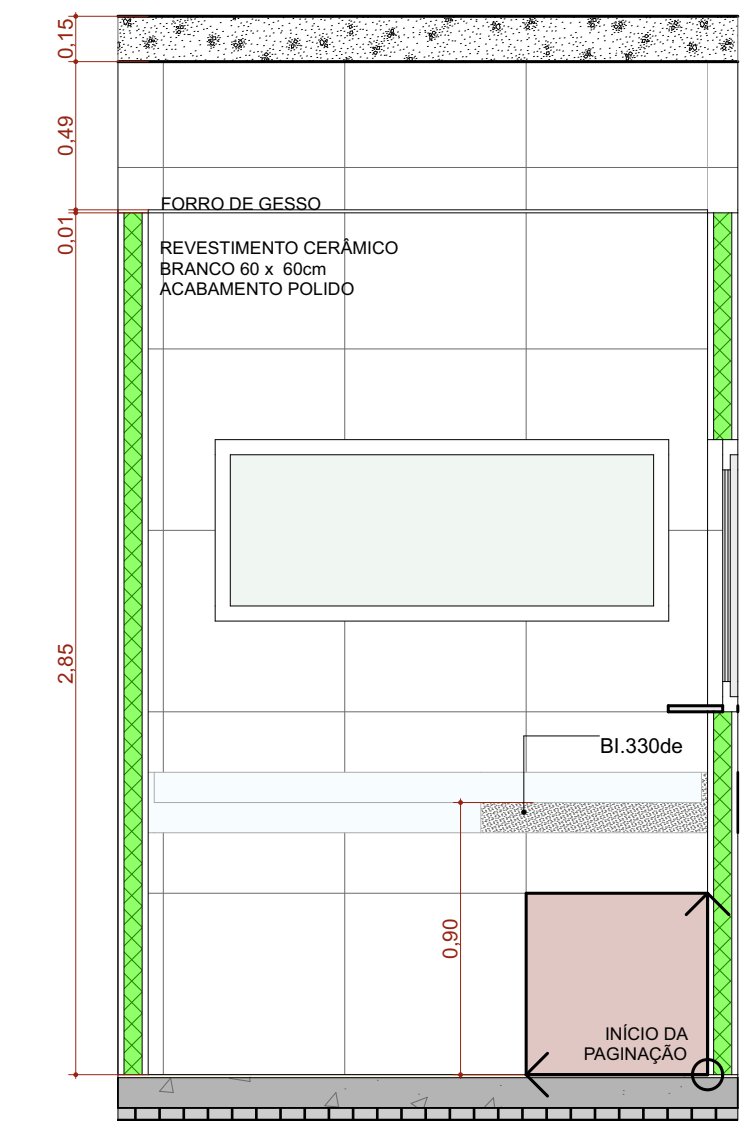

A.M.06 VISTA 1
Escala: 1:25

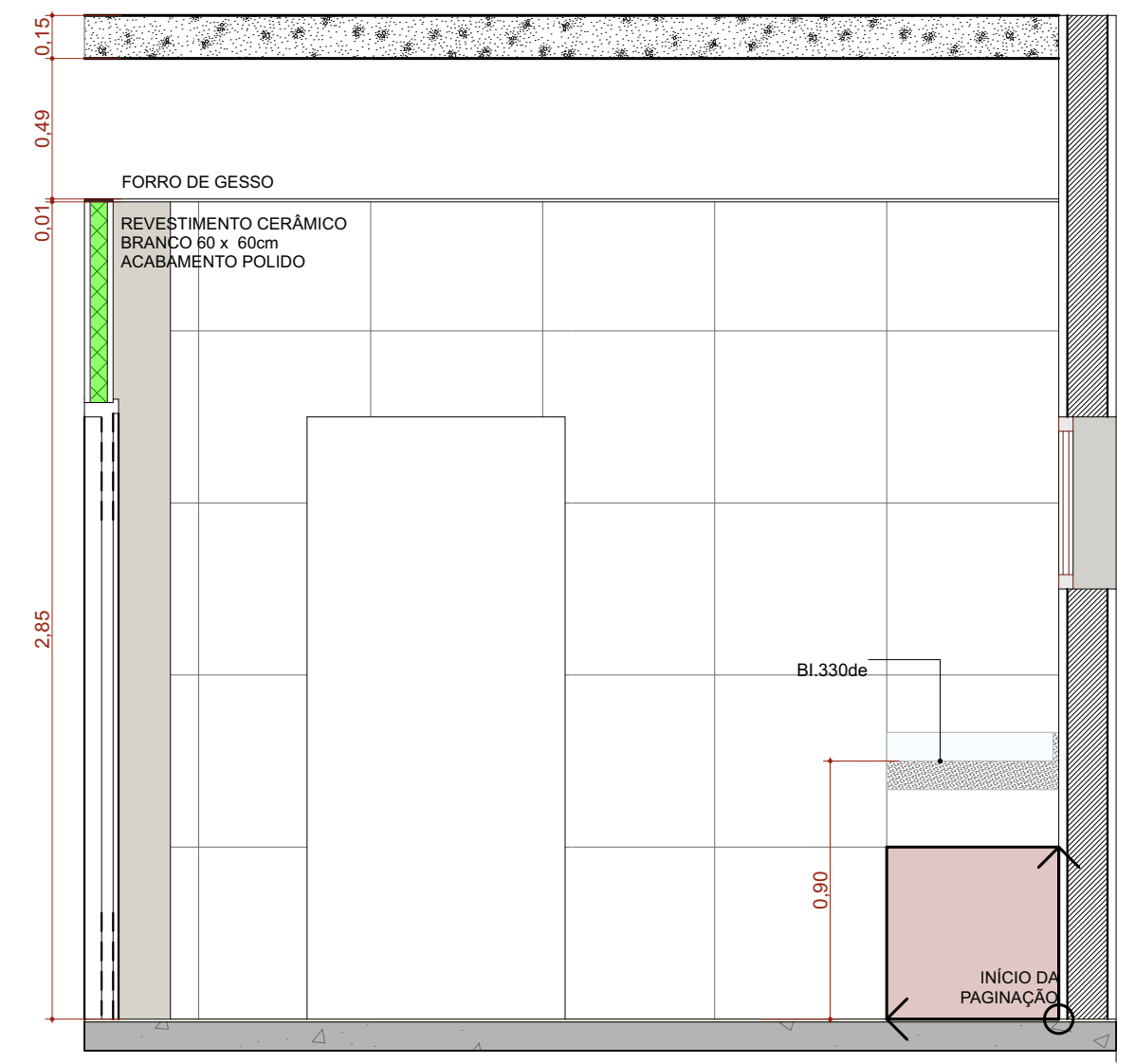

A.M.06 VISTA 2
Escala: 1:25

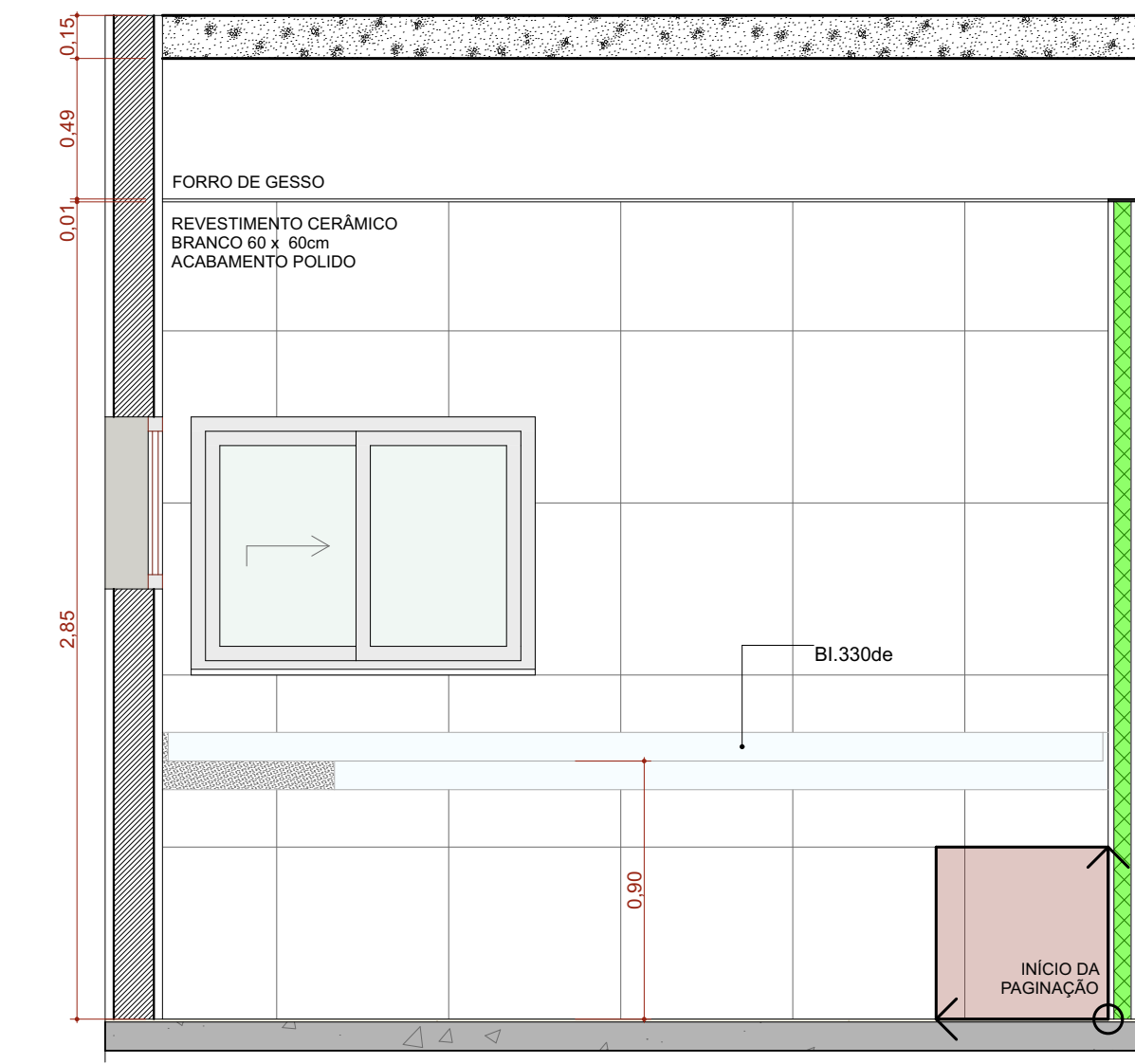

A.M.06 VISTA 3
Escala: 1:25

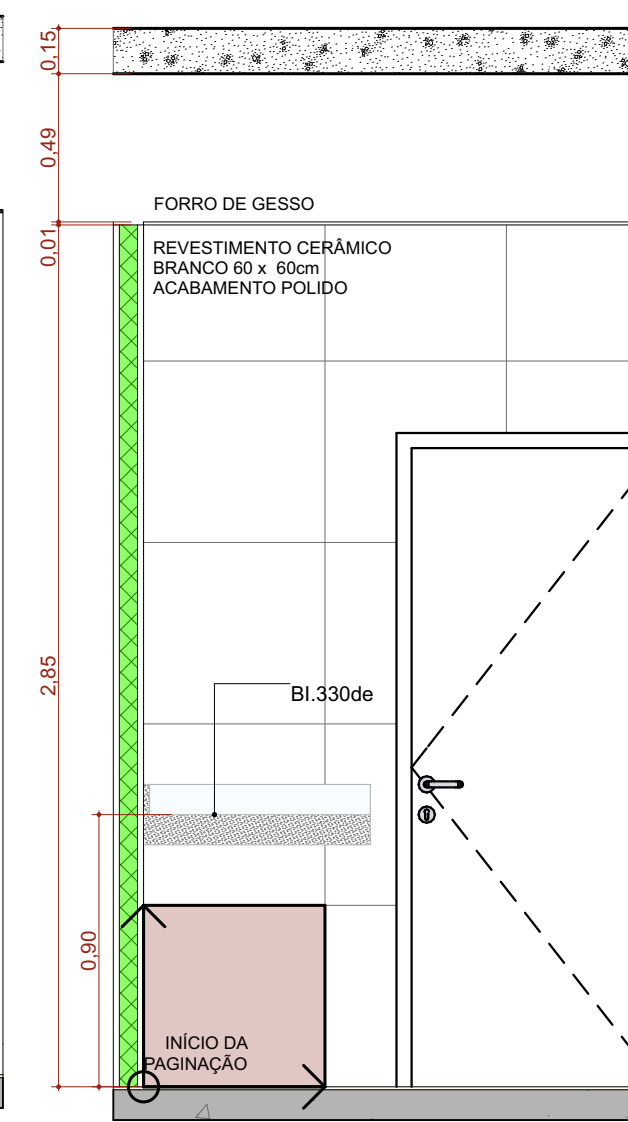

A.M.06 VISTA 4
Escala: 1:25

TÍTULO DO PROJETO
UNIDADE BÁSICA DE SAÚDE - PORTE 1
PROPRIETÁRIO
MINISTÉRIO DA SAÚDE
SECRETARIA DE ATENÇÃO PRIMÁRIA À SAÚDE
CNPJ
00.394.544/0108-14



INSTRUMENTO
Secretaria de Atenção Primária à Saúde
Eplanada dos Ministérios Bloco G Edifício Sede - Ministério da Saúde
CEP 70.058-900 - Brasília- DF

TÍTULO DO PROJETO
DETALHAMENTO ÁREAS MOLHADAS 01

DESCRIÇÃO DA ETAPA
PROJETO EXECUTIVO

NOME PRANCHETA / ARQUIVO	REVISÃO	UNIDADE	DATA	ESCALA
MS_UBS1_PE_AQ_11.12_R00	R01	METROS	04/09/2024	INDICADA

DIRETOS AUTORES RESERVADOR CONFORME LEGISLAÇÃO NACIONAL E INTERNACIONAL

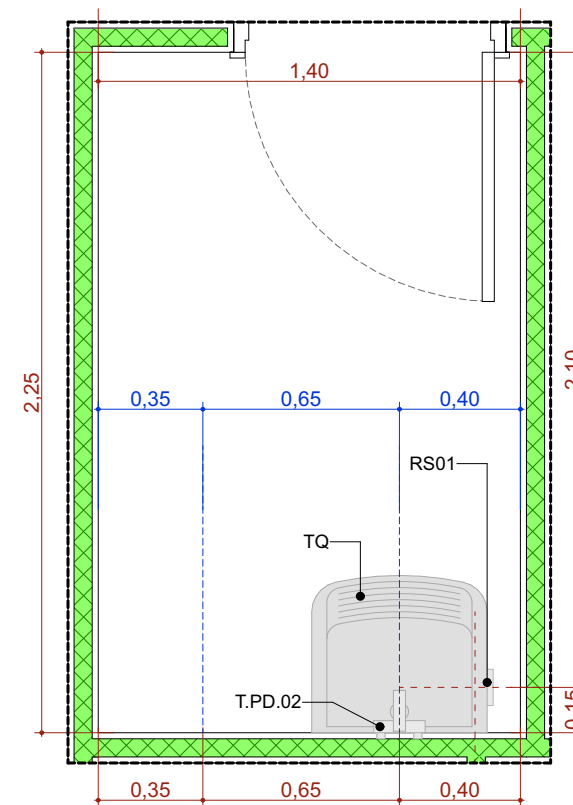

A.M.7 DML
Escala:1:25

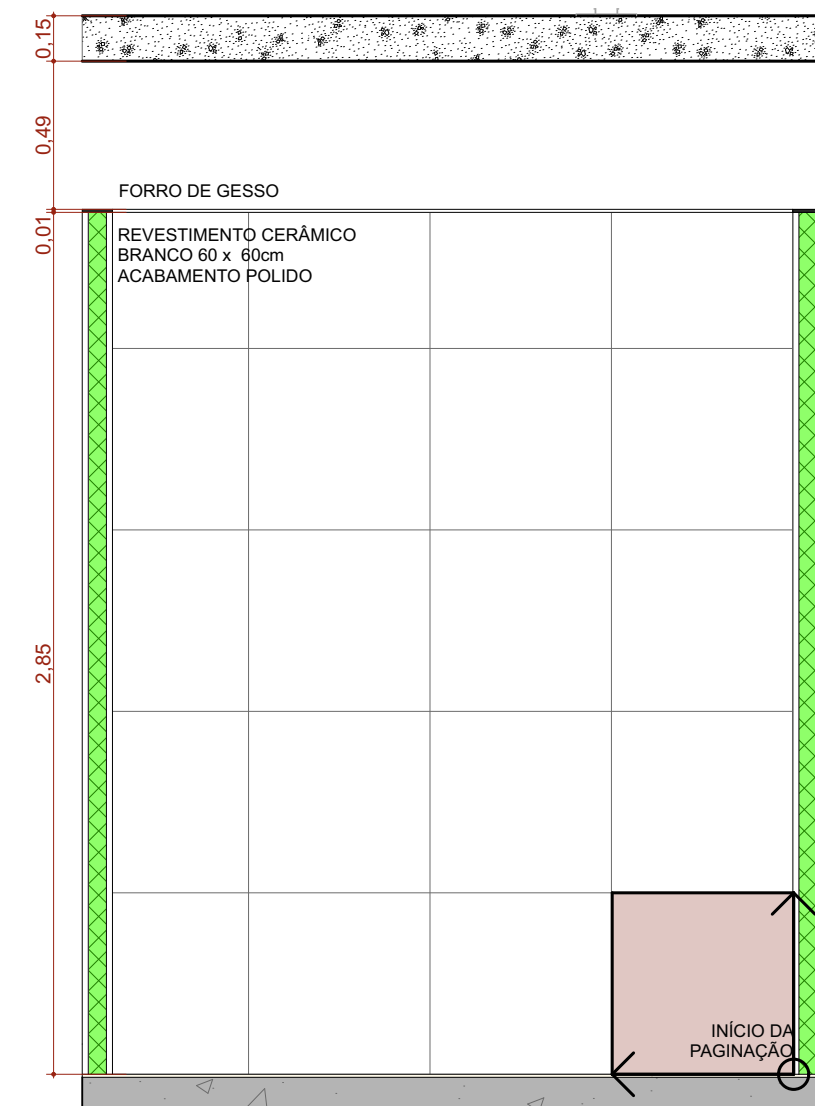

A.M.07 VISTA 1
Escala:1:25

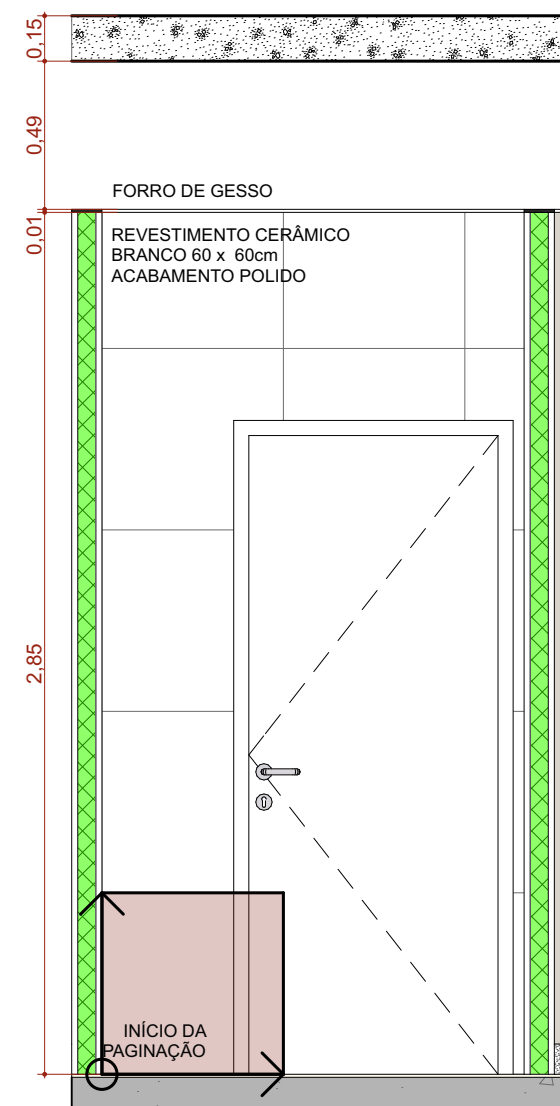

A.M.07 VISTA 2
Escala:1:25

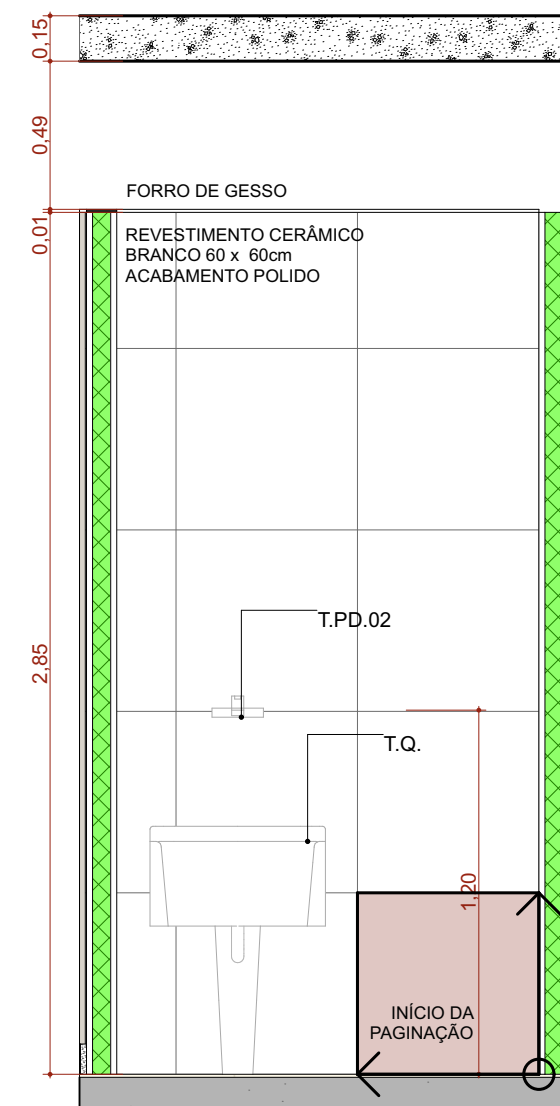

A.M.07 VISTA 3
Escala:1:25

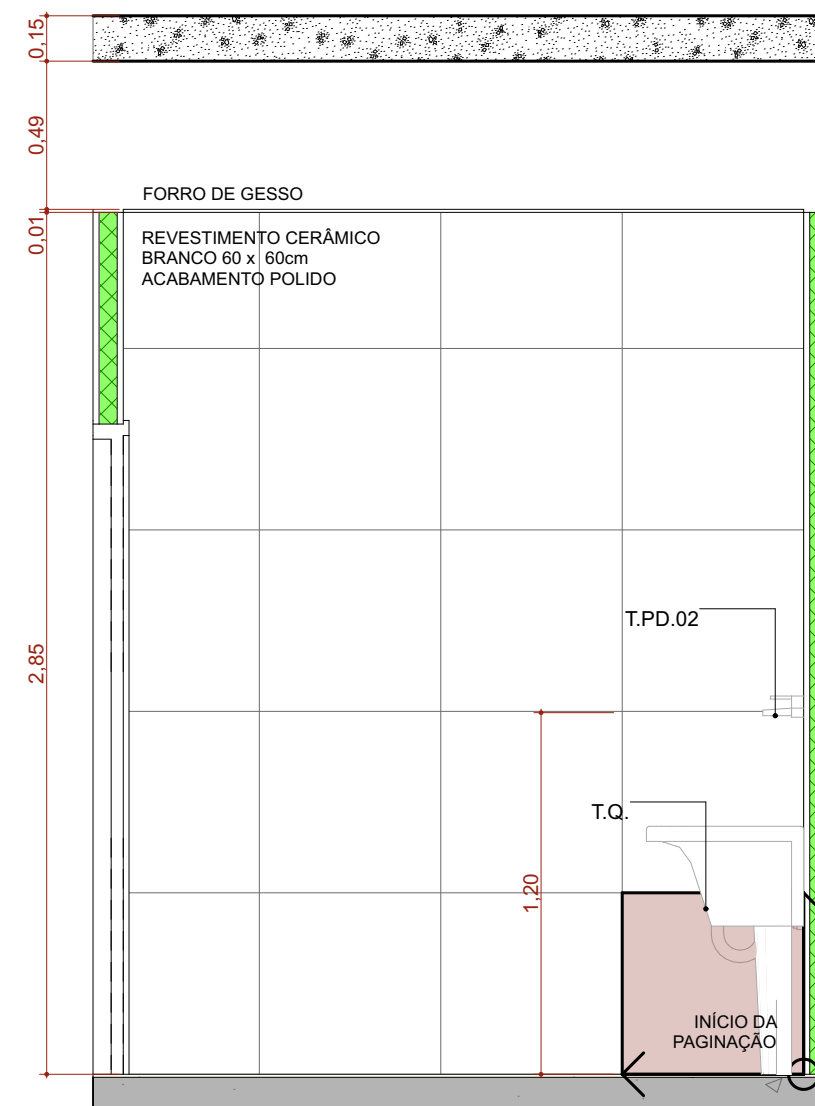

A.M.07 VISTA 4
Escala:1:25

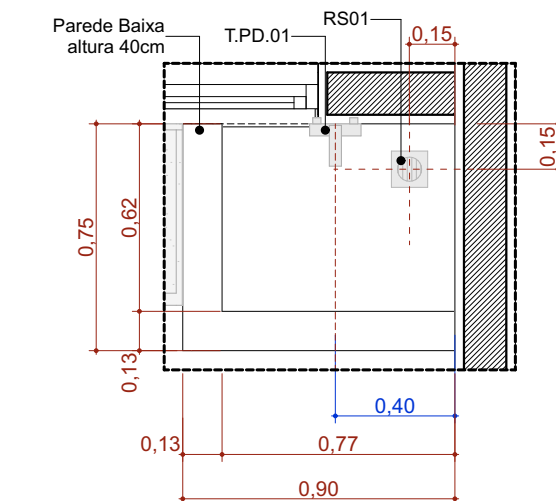

A.M.10 Higienização dos pés
Escala:1:25

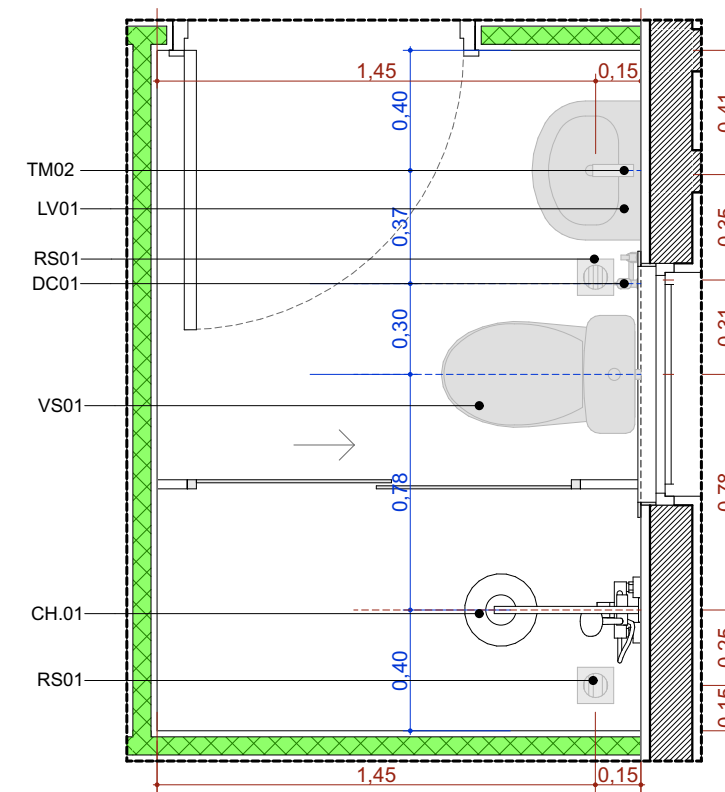

A.M.8 Banh. Func. Masc.
Escala:1:25

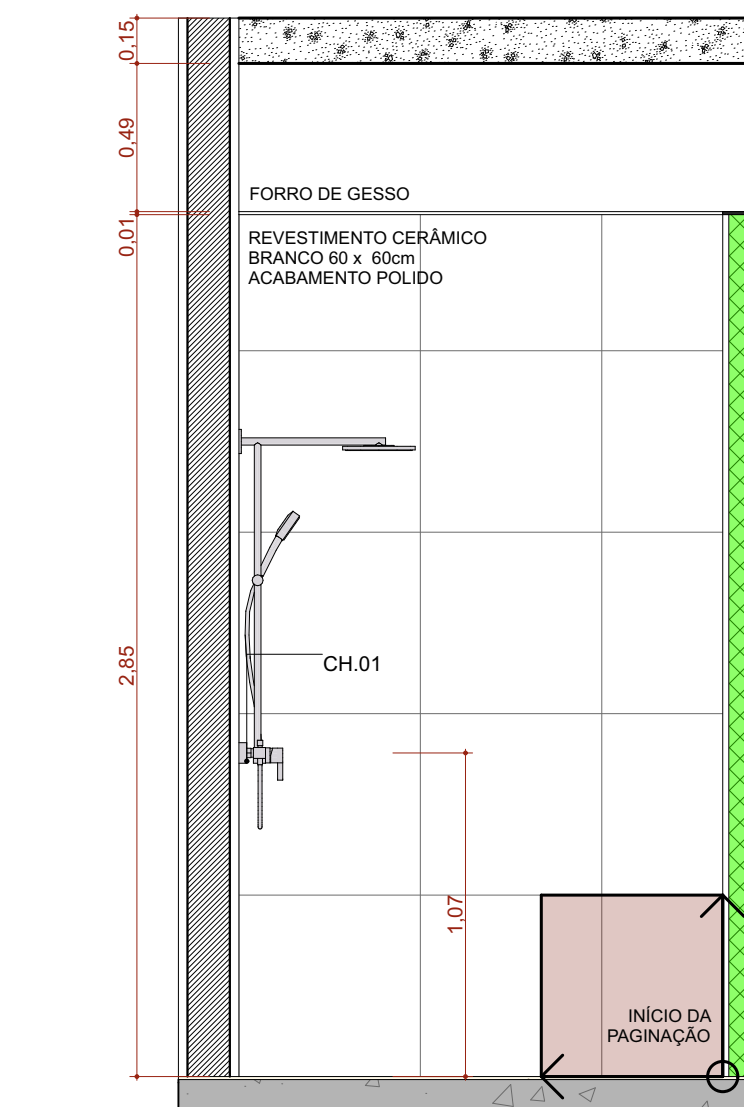

A.M.08 VISTA 1
Escala:1:25

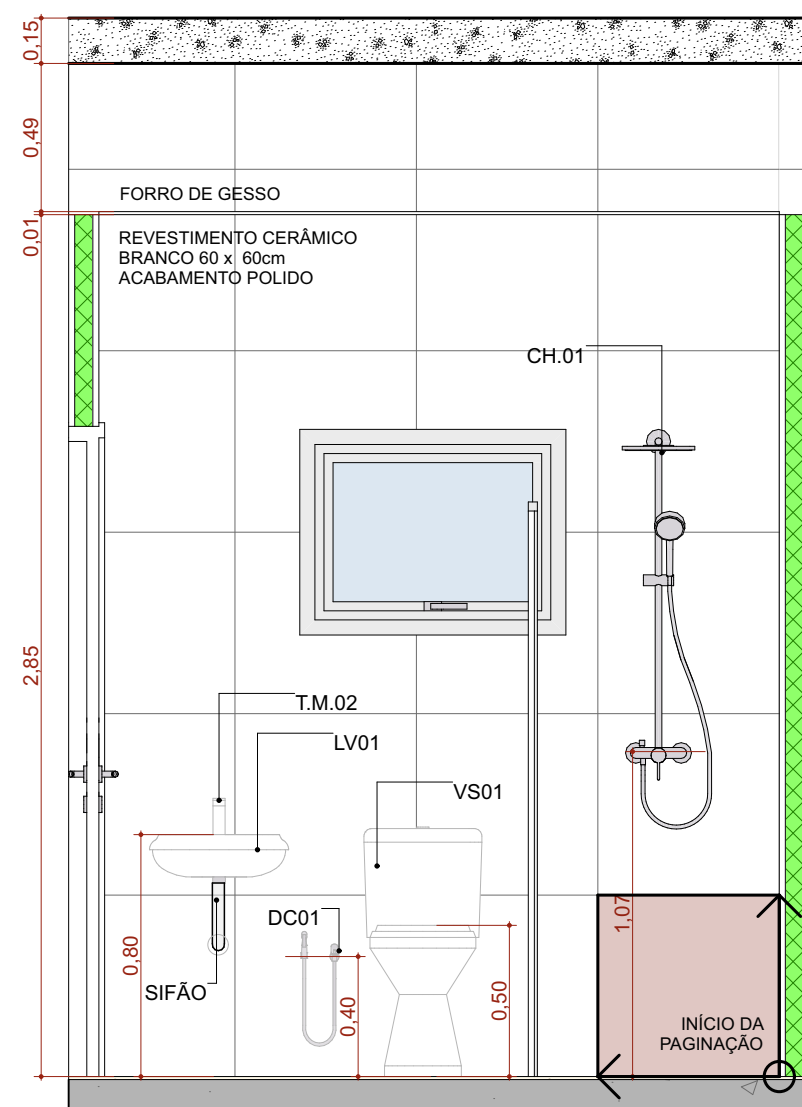

A.M.08 VISTA 2
Escala:1:25

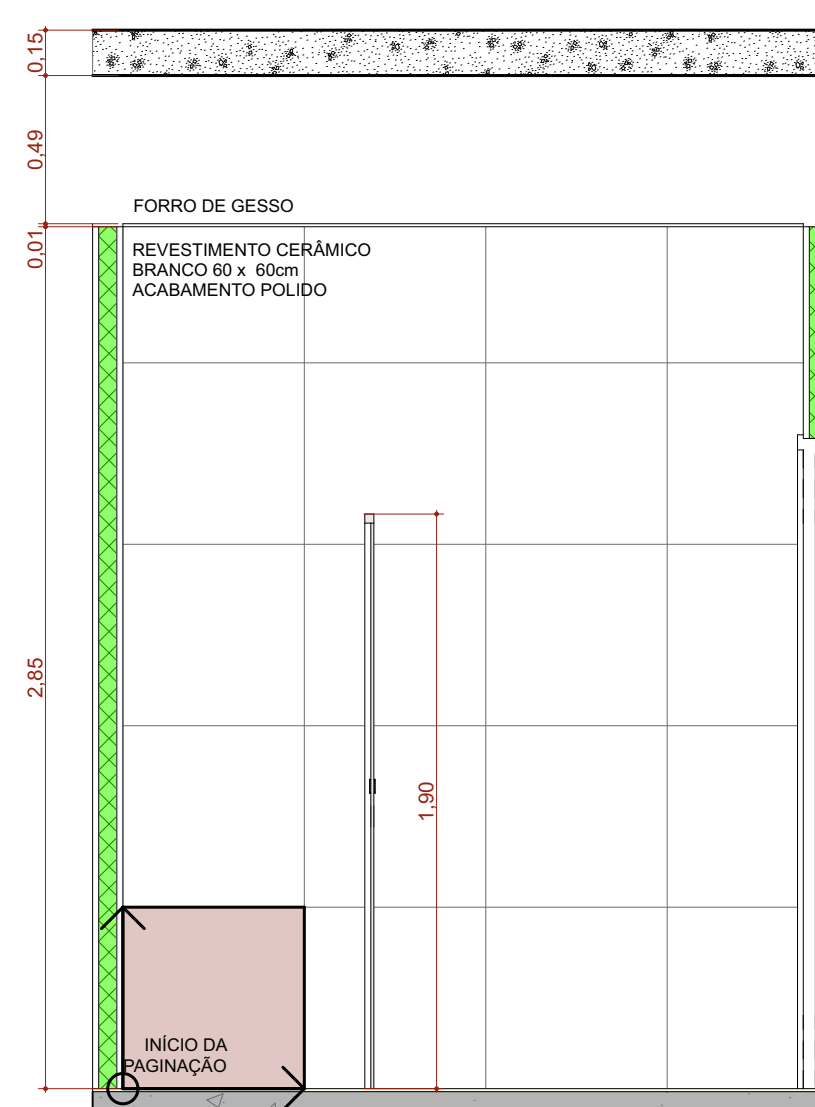

A.M.08 VISTA 3
Escala:1:25

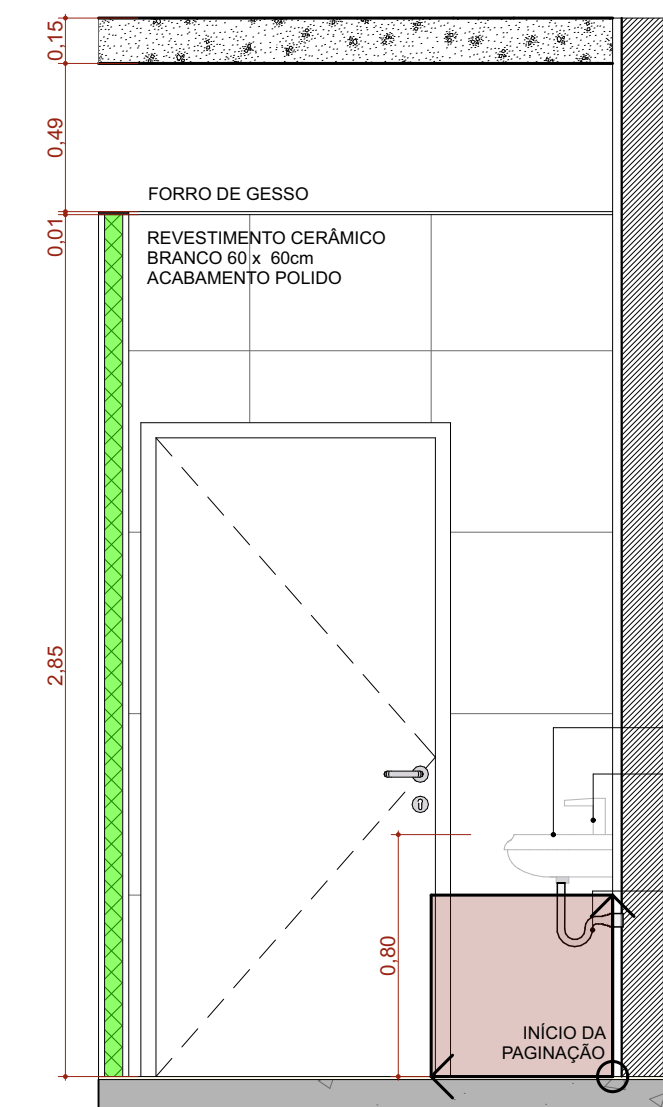

A.M.08 VISTA 4
Escala:1:25

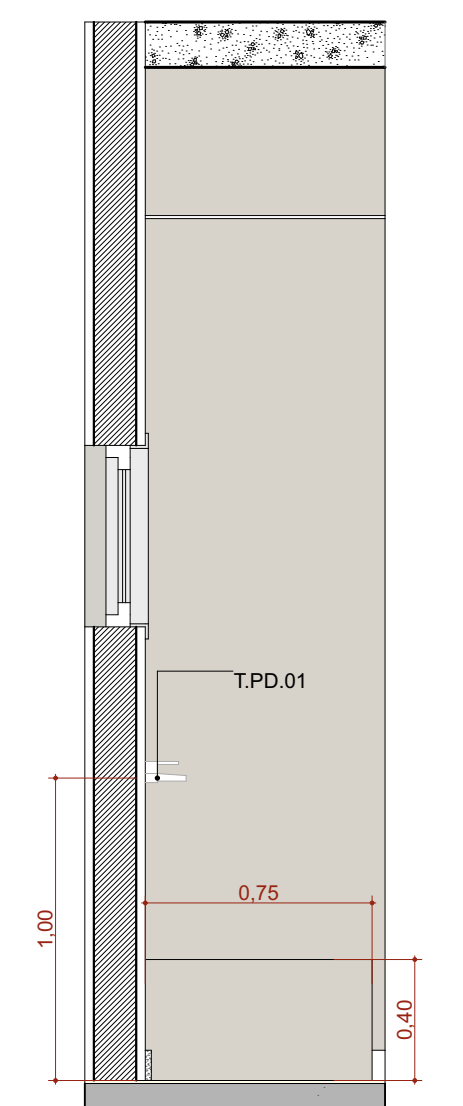

A.M.10 VISTA 1
Escala:1:25

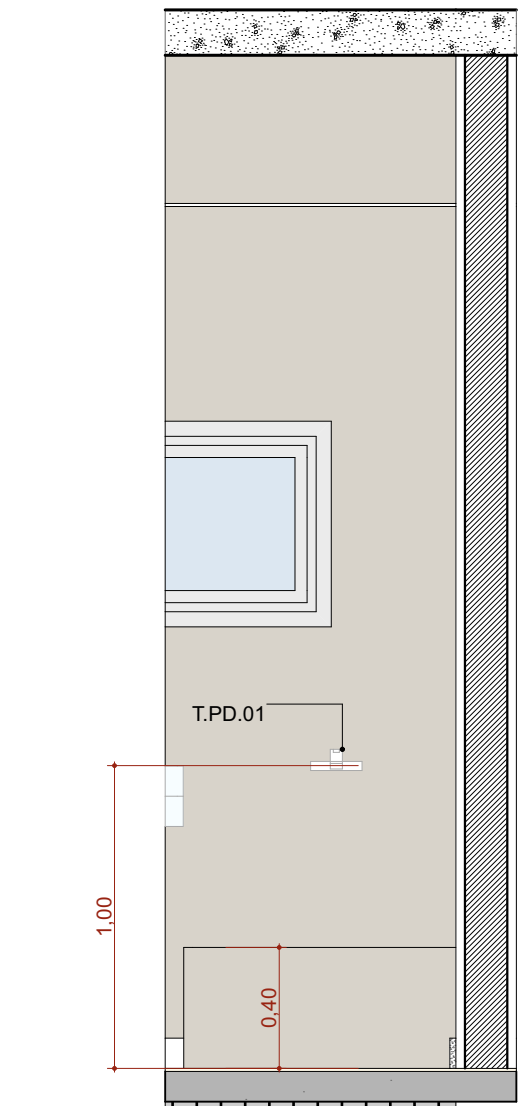

A.M.10 VISTA 2
Escala:1:25

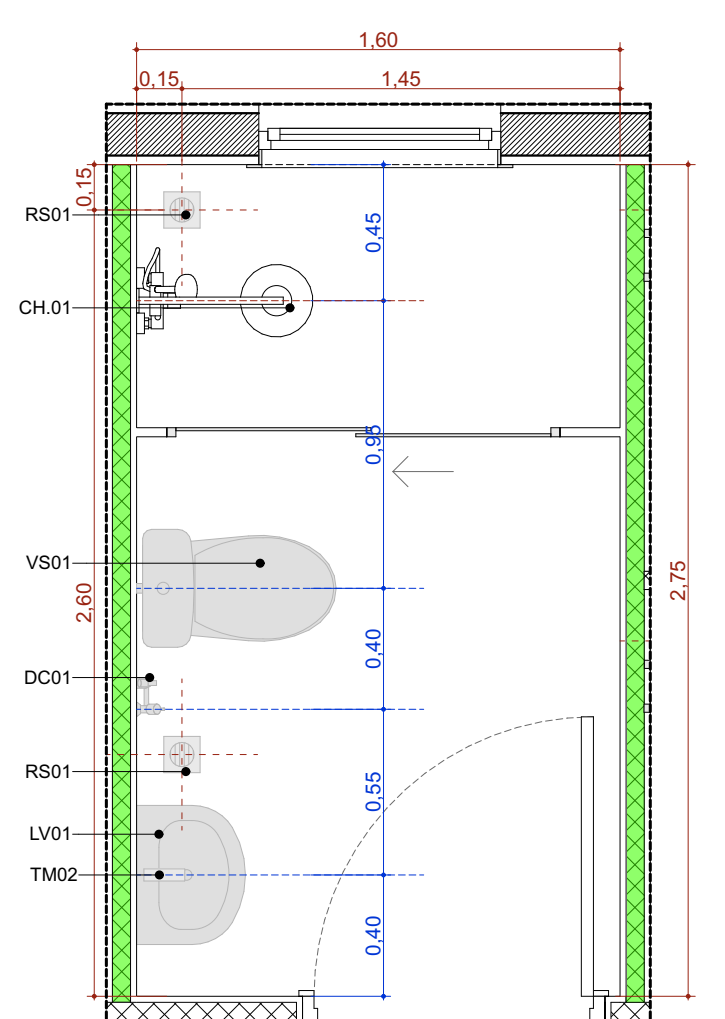

A.M.9 Banh. Func. Fem.
Escala:1:25

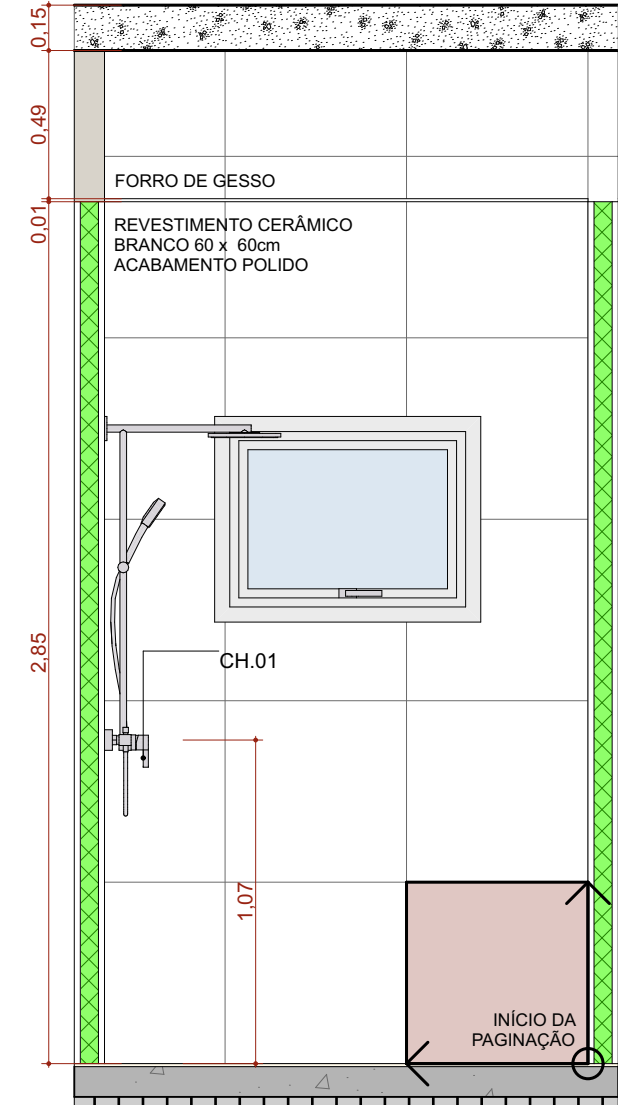

A.M.09 VISTA 1
Escala:1:25

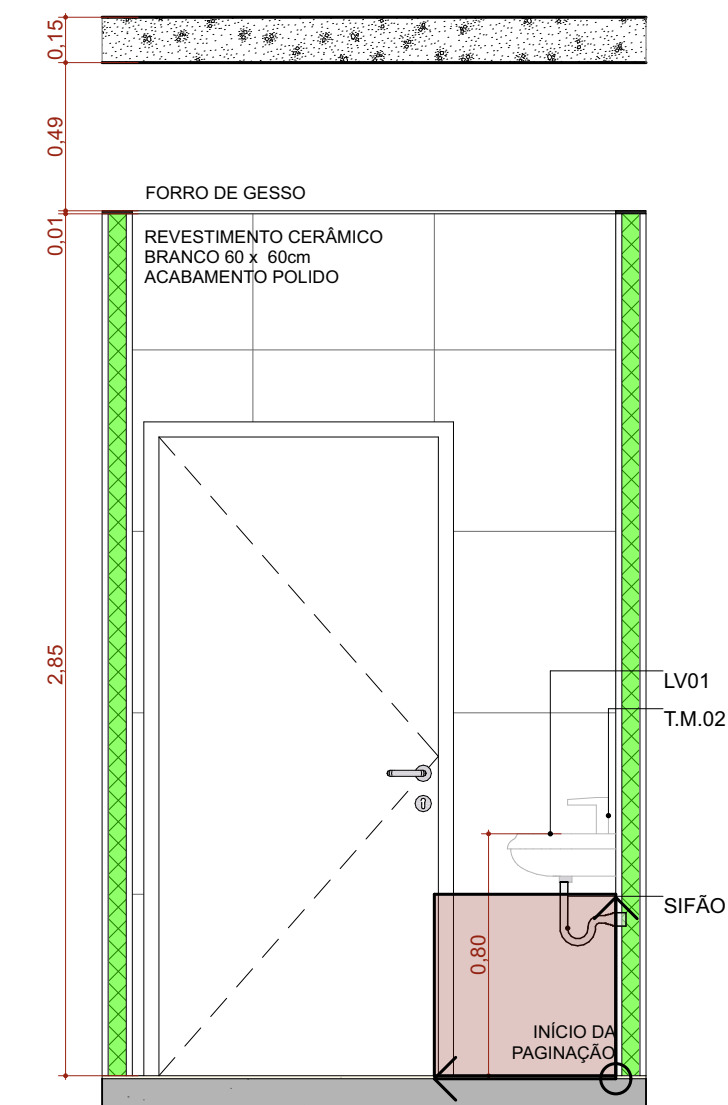

A.M.09 VISTA 2
Escala:1:25

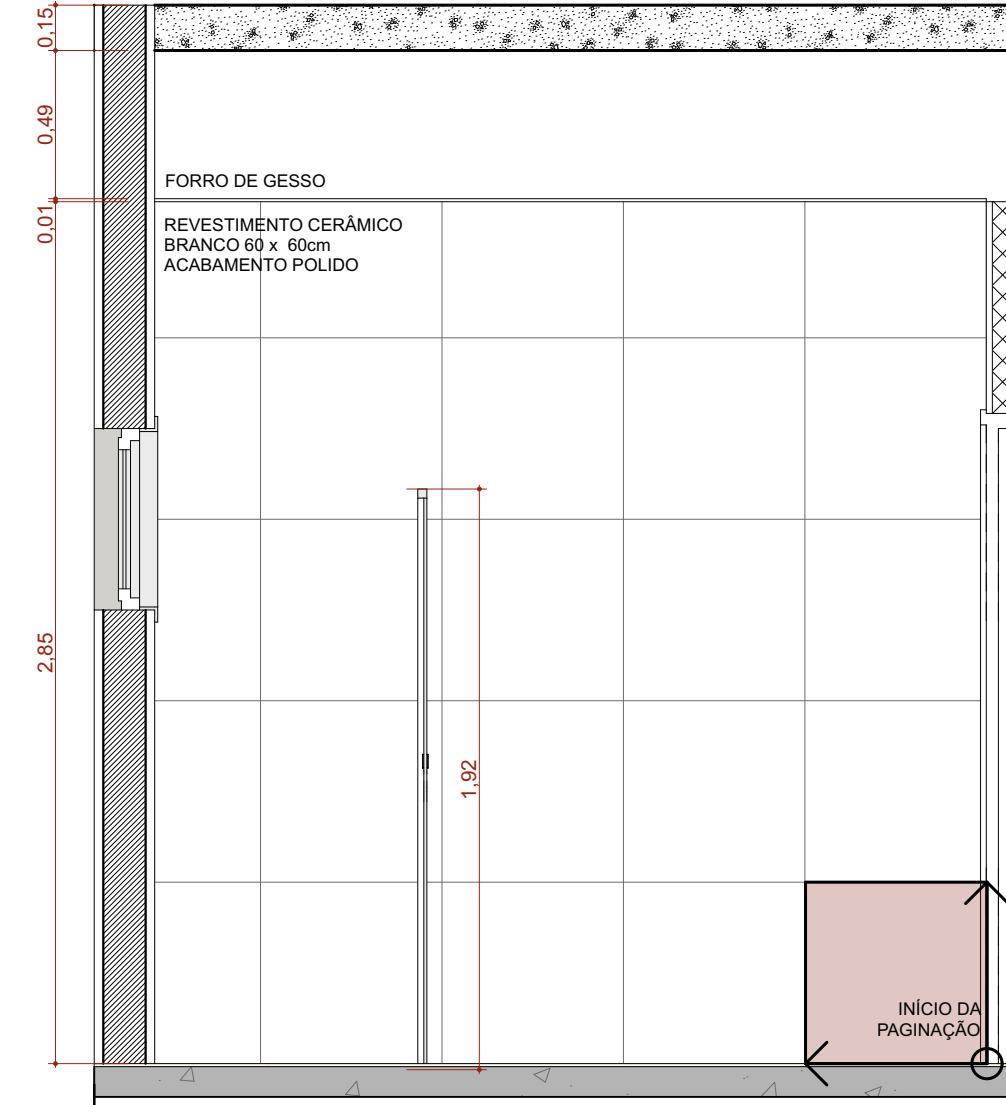

A.M.09 VISTA 3
Escala:1:25

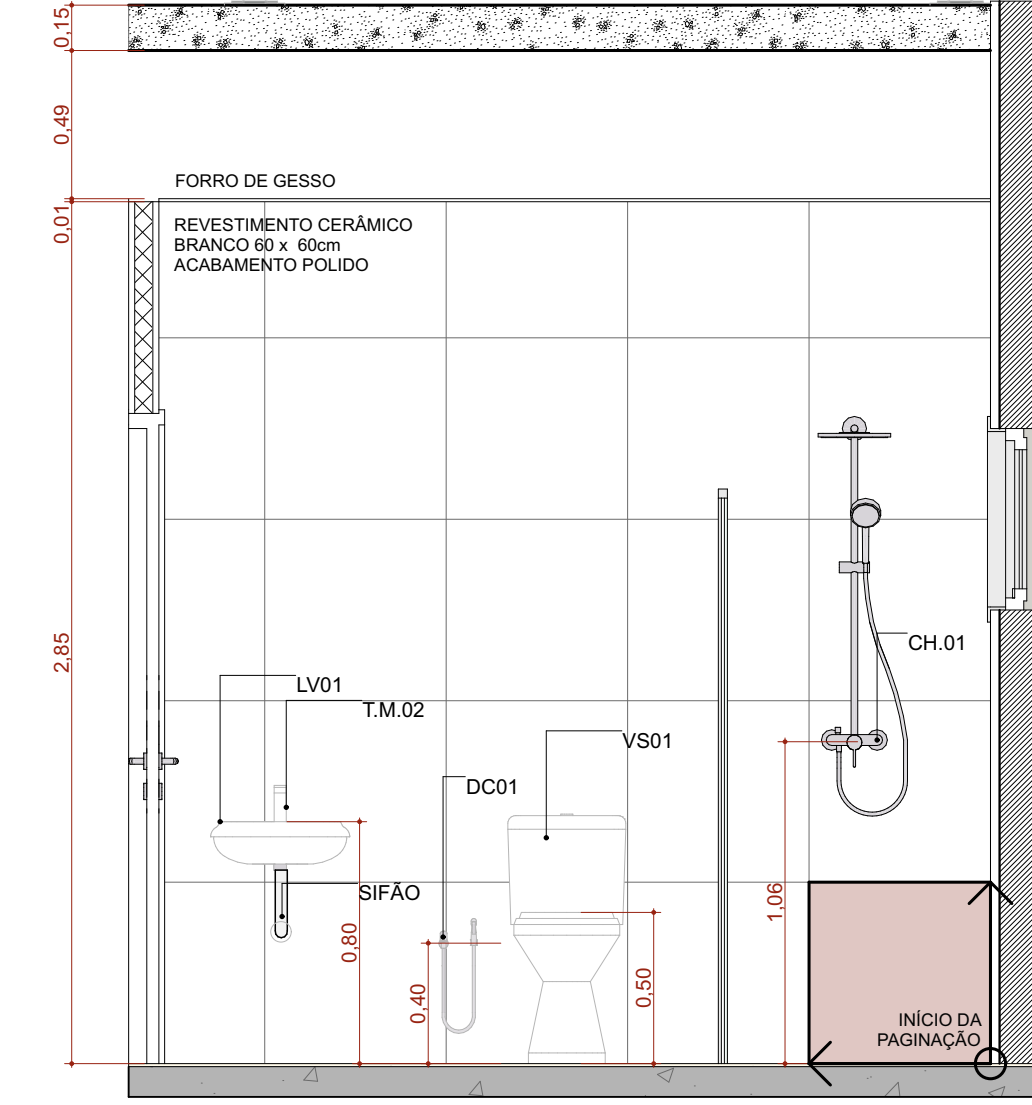

A.M.09 VISTA 4
Escala:1:25

TÍTULO DO PROJETO
UNIDADE BÁSICA DE SAÚDE - PORTE 1
PROPRIETÁRIO
MINISTÉRIO DA SAÚDE
SECRETARIA DE ATENÇÃO PRIMÁRIA À SAÚDE
CNPJ
00.394.544/0108-14
ENDEREÇO
Secretaria de Atenção Primária à Saúde
Esplanada dos Ministérios Bloco G Edifício Sede - Ministério da Saúde
CEP 70. 058-900 - Brasília- DF



DETALHAMENTO ÁREAS MOLHADAS 02

DESCRIÇÃO DA ETAPA
PROJETO EXECUTIVO

NOME: PRANCHA - ARQUIVO MS_UBS1_PE_AQ 12.12_R00	REVISÃO R01	UNIDADE METROS	DATA 04/09/2024	ESCALA INDICADA
---	-----------------------	--------------------------	---------------------------	---------------------------